Fax Developer's Guide

Classes 2 and 2.0/2.1



Classes 2 and 2.1 Fax Developer's Guide

Product Number S0000239D, Revision D

Copyright

Copyright © 2002-2007 by Multi-Tech Systems, Inc.

All rights reserved. This publication may not be reproduced, in whole or in part, without prior expressed written permission from Multi-Tech Systems, Inc.

Multi-Tech Systems, Inc. makes no representation or warranty with respect to the contents hereof and specifically disclaims any implied warranties of merchantability or fitness for any particular purpose. Furthermore, Multi-Tech Systems, Inc. reserves the right to revise this publication and to make changes from time to time in the content hereof without obligation of Multi-Tech Systems, Inc., to notify any person or organization of such revisions or changes.

Revision	Date	Description
A	11/15/01	Beta version.
B	08/05/02	Release version.
C	05/25/07	Added Fax S-Registers. Added debugging commands.
D	12/13/07	On page 10 changed the sequence to send MMR data over a non-MMR session from <DLE><0x6F> to <DLE><0x6E>.

Trademarks

The Multi-Tech logo is a registered trademark of Multi-Tech Systems, Inc.

Home Office

Multi-Tech Systems, Inc.
2205 Woodale Drive
Mounds View, Minnesota 55112
Phone: 763-785-3500 or 800-328-9717
Fax: 763-785-9874
Internet: <http://www.multitech.com>

Table of Contents

Chapter 1 – Introduction	5
1.1 Introduction	5
1.2 AT Command Implementation	5
1.3 Modes of Interaction	7
1.3.1 AT Command Mode.....	7
1.3.2 Command Execution Mode	8
1.3.3 Data Transfer Mode.....	8
Chapter 2 – Commands and Responses	11
2.1 Overview	11
2.1.1 Action Commands	11
2.1.2 Modem Responses.....	11
2.1.3 Parameters for Mandatory Services	12
2.1.4 Parameters for Optional Services.....	13
2.2 Identification Commands	14
2.2.1 Service Class Indication	14
2.2.2 Service Class Capabilities	14
2.2.3 Service Class Selection	15
2.2.4 Request Manufacturer Identification.....	15
2.2.5 Request Model Identification	15
2.2.6 Request Revision Identification	16
2.3 Action Commands.....	16
2.3.1 Originate a Call	16
2.3.2 Answer a Call.....	17
2.3.3 Data Transmission.....	17
2.3.4 Post-Page Message Release	18
2.3.5 Data Reception	18
2.3.6 Session Termination	18
2.3.7 Initialize Facsimile Parameters.....	19
2.4 Modem Responses	20
2.4.1 T.30 Phase A Negotiation Responses.....	20
2.4.2 T.30 Phase B Negotiation Responses.....	21
2.4.3 T.30 Phase C Page Reception Responses	24
2.4.4 T.30 Phase D Post Page Responses	25
2.4.5 Call Termination with Status	26
2.5 Parameter Commands.....	28
2.5.1 T.30 Session Parameters	28
2.5.2 T.30 Procedure Control Parameters.....	39
2.5.3 Phase C Data Format Parameters	45
2.5.4 Miscellaneous Parameters	53
2.6 Session Message Report Responses.....	53
2.6.1 Report Transmit HDLC Frames, +FHT:.....	53
2.6.2 Report Received HDLC Frames, +FHR:	53
2.7 Debug Message Report Responses.....	54
2.7.1 Report Debug Messages, +FDB:.....	54
2.7.2 Debug Message Display in Page Transfer Modes	54
Chapter 3 – Fax S-Registers	55
3.1 Command +FS.....	55
Appendix A – Sample Modem Control Sessions	56
A1. Send two pages, 1-D data, no errors (Class 2)	56
A2. Receive two pages, 1-D data, no errors (Class 2).....	57

A3. Send two pages, 1-D data, no errors (Class 2.0)58

A4. Receive two pages, 1-D data, no errors (Class 2.0).....59

A5. Originate and send a two page facsimile with V.34 half-duplex (Class 2.1).....60

A6. Answer and receive a two-page facsimile with V.34 half-duplex (Class 2.1)61

Appendix B – Alphabetic List of Commands and Responses.....62

Appendix C – ASCII Conversion Chart.....64

Appendix D – +FBU/+FDB/+FBU Interactions65

 Overview65

Index66

Chapter 1 – Introduction

1.1 Introduction

This document summarizes the fax Service Class 2 and Service Class 2.0/2.1 command sets as implemented in Multi-Tech Systems, Inc., MultiModems. All Multi-Tech modems support Class 2 fax commands. Some support Class 2.0. Some support Classes 2.0 and 2.1. To determine which command classes your modem supports, query the modem with the +FCLASS=? command (see section 2.2.2 of this manual). It is assumed that users are familiar with ITU-T Recommendation T.32, including Amendment 1, and have an understanding of ITU-T T.30 and T.4 concepts. ITU-T documents can be purchased from the ITU at <http://www.itu.int/publications/index.html>.

The Service Class 2.0 command set applies to facsimile communications at speeds up to 14 400 bits per second (bps). The Service Class 2.1 command set is a modification of the Class 2.0 command set for facsimile communications at V.34 speeds up to 33 600 bits per second (bps), as documented in ITU-T T.32 Amendment 1. Because the two command sets differ only in subparameter values for a few Class 2.1 commands, they are treated here as a single Class 2.1 command set with differences noted as appropriate.

The Multi-Tech implementation of Class 2.1 follows ITU-T Recommendation T.32 as amended, except for a few subparameter values. Again, differences are noted as appropriate.

This document also summarizes the Multi-Tech implementation of the Service Class 2 command set, which was based on EIA proposed standard TIA-592 (August, 1990). The complete Multi-Tech Class 2 Developer's Kit can be downloaded from <http://www.multitech.com/DOCUMENTS/manuals/82006502.pdf>. EIA/TIA documents can be purchased from Global Engineering Documents at <http://global.ihs.com/>.

Please note that the Class 2 and Class 2.0 commands though similar in outline are sometimes quite different in detail. Class 2 is a proposed early version of Class 2.0 that was never approved, but was widely implemented by modem manufacturers. As a result, all implementations of Class 2 are non-standard and manufacturer-specific. Class 2.0 is the version of Class 2 that was approved by the ITU after substantial changes to the original proposal. Major changes include a shortening of command names to three characters, a change from decimal values to hexadecimal values, the elimination of some commands, and the addition of others.

This document is organized so that Class 2 commands are described with and compared to the equivalent Class 2.1 commands.

1.2 AT Command Implementation

The best way to get an understanding of how Class 2.1 commands or responses are used is to present an example of the transmission and reception of a one-page fax using Class 2.1.

Below are the commands and responses given to and returned from the transmitting and receiving modems. Commands are shown in upper case, responses in lower case.

Transmitting Modem			Receiving Modem		
Line #	Command/response	Comments	Line #	Command/response	Comments
T1	AT+FCLASS=2.1	Set class to originate as a fax modem	R1	AT+FCLASS=2.1	Set class to answer as a fax modem. Tell the modem the host can receive documents and to auto-detect the calling modem. Required setting: +FCLASS=2.1
T2	ok		R2	ok	
	AT+FNR = 1,1,1,1	Enable all fax responses.		AT+FNR = 1,1,1,1	Enable all fax responses.
T3	AT+FLI="666 6676"	Set local fax ID	R3	AT+FLI="555 1212"	Set local fax ID
T4	ok		R4	ok	
T5	ATDT5551212	Dial the receiving fax modem	R5	ring	
T6	+FCO	Fax connection received			
T7	+fci:"555 1212"	Remote fax's identification string			
T8	+fis:0,5,0,2,0,0,0,0	Remote fax's capabilities			
T9	ok				
T10	AT+FDT	Begin negotiation and page transmission			
			R7	+FCO	Fax connection received
			R8	+fti:"666 6676"	Remote fax's identification string
			R9	+fcs:0,5,0,2,0,0,0,0	Negotiated fax parameters (speed may change)
			R10	ok	
			R11	AT+FDR	Begin page reception
T11	+fcs:0,5,0,2,0,0,0,0	Negotiated fax parameters	R13	+fcs:0,5,0,2,0,0,0,0	Final negotiated fax parameters
T12	connect	Ready for page data	R14	connect	Ready to receive page data
T13			R15	<DC2>	
T14	<page data>	Send T.4 formatted page data	R16	<page data>	Receive T.4 formatted page data
T15	<DLE><EOP>		R17	+fps:1000,0,0,0	1000 lines received
T16		This is the last page	R18	+fet:2	This is the last page
			R19	ok	
			R20	AT+FDR	Send page received OK message
T18	+fhs:0	Send one page done	R21	+fhs:0	Receive one page done
T19	ok		R22	ok	

We can now use the example to help explain the terminology for the fax command extensions.

1.3 Modes of Interaction

The modem has three modes of interaction: AT command mode, command execution mode, and data transfer mode.

In AT command mode, serial data sent to the modem is interpreted as commands when preceded by the characters *AT*.

Command execution mode follows AT command mode when an action command, such as a dialing command, is sent to the modem. The modem responds to an action command by displaying responses that indicate the progress of the command and also information received from the remote fax modem. If serial data is received at that point, the fax is aborted and the phone call terminated.

Data transfer mode begins after a +FDT or +FDR command is entered from AT command mode, the command is executed, and a *CONNECT* response is given. When a +FDT command is used to enter data transfer mode, the serial data sent to the modem should be image data for the page being transmitted, as specified by the ITU-T T.4 standard. When a +FDR command is used to enter data transfer mode, the serial data received from the modem should be image data for the page currently being received.

1.3.1 AT Command Mode

In AT command mode, both regular AT commands and fax AT commands can be sent. Regular AT commands are used to control data modem functions and functions common to both modem and fax operation, such as dialing (ATD) and answering (ATA). Fax AT commands begin with the characters +F followed by a command name followed by either “?” if reading a parameter, “=” followed by a parameter value if setting a parameter, or “=?” if inquiring the valid values of a parameter. Any AT command that follows a fax AT command must be separated from it by a semicolon.

Fax AT command types. There are two types of fax AT commands: action commands and parameter commands. Action commands initiate a sequence of events that change command mode to command execution mode, and therefore do not execute instantaneously. Because of this mode change, an action command must be the last command in a command line. In contrast, parameter commands execute immediately; therefore more than one can appear in the same command line.

Parameter command types. There are three types of parameter commands: set a parameter, read a parameter, and read the valid values for a parameter.

Note: When receiving fax responses from the modem, the state of the regular AT parameter V is important. If verbose mode is enabled (set by issuing the ATV1 command), then all responses will be preceded and followed by a <CR><LF> combination. If terse mode is enabled (set by issuing the ATV0 command), then all responses will be followed by <CR> only. Also, regular AT responses are affected by the same V parameters (e.g., verbose response: *OK*, terse response: *1*). All examples in this document assume verbose mode.

Responses. When a parameter is set, the response is *OK* if the parameter value is valid; the response is *ERROR* if the parameter value is invalid. When a parameter is read, the response has the following format: +F<parameter_name>=<value>. When the valid values for a parameter are requested, the response is given as a valid parameter string as described below. When action commands are given, responses may be given to report the progress of the action command. For example, the ATD command may give the responses +FCO, +FIS:0,2,2,2,0,0,0,0 before the *OK* response is given.

Responses to action commands have the following format:
 +F<parameter_name>:<value>, for legacy modems operating in Class 2 mode;
 <value>, in all other cases.

Parameter types. There are three types of parameters: numeric, character string, and compound.

Numeric parameters are hexadecimal numbers in the range 0–FFh (0–255 decimal) or 0–FFFFh (0–65535 decimal), depending on the parameter being set or read. Any number of leading zeros is permissible. A valid values string for numeric parameters consists of a list of numbers and/or number ranges separated by commas. Number ranges consist of two values separated by a hyphen. For example, (A, 14-17, 1e) means the valid parameter values are Ah, 14h, 15h, 16h, 17h, and 1Eh (10, 20, 21, 22, 23, and 30 in decimal notation).

String parameters consist of a string of characters enclosed by double-quote characters. The string may not contain non-printable characters or double-quote characters. A valid values string for string parameters consists of a list of valid character values and character value ranges in hexadecimal format separated by commas and enclosed in parentheses. For example, (20, 2b, 30-39) means the string can consist of the space character (20h), the plus character (2Bh), and the characters 0–9 (30h–39h).

Compound parameters consist of a list of numeric and string parameters separated by commas. For example, the compound parameter DIS consists of eight numeric parameters set by the following command AT+FIS=*n,n,n,n,n,n,n,n*). It is possible to omit values from a compound parameter either by omitting values in the parameter string or by truncating the parameter string. For example, the command AT+FIS=.,,2,0 sets only the third and fourth values of the DIS parameter and leaves the rest unchanged. Note that when you omit leading parameters, you must leave their separation commas as place holders, but trailing parameters and their commas can simply be omitted. It is possible to receive a compound parameter response from the modem that will have missing values. For example, the +FPS response sometimes has only two values (+FPS:1,1134) and other times has five values (+FPS:1,1134,30,4,0), depending on the setting of the +FCQ parameter. A valid values string for a compound parameter consists of a valid values string for each parameter enclosed in parentheses and separated by commas. Example: +FIS (0-1), (0-3), (0-4), (0-2), (0), (0), (0), (0-7).

The following table illustrates how each of the parameter types is set or read, with typical responses.

Parameter type	Set	Read	Read valid values
Numeric	AT+FLP=1 ok	AT+FLP? 1 ok	AT+FLP=? 0,1 ok
String	AT+FLI="123" ok	AT+FLI? "123" ok	AT+FLI=? (20) (32 -127) ok
Compound	AT+FIS=.,,2,0 ok	AT+FIS? 0,1,1,0,0,0,0,4 ok	AT+FIS=? (0-1), (0-3), (0-4), (0-2), (0), (0), (0-7) ok

1.3.2 Command Execution Mode

In command execution mode, responses indicate the progress of an action command. Response format is the same as the format of a parameter that is read except that "=" following the parameter name is replaced by ":". All action commands can be aborted by sending a single byte of serial data to the modem while it is in command execution mode. This not only aborts the command, but initiates the fax disconnect sequence.

1.3.3 Data Transfer Mode

Data transfer mode is entered after the *CONNECT* response is given (or a 1 response is given in terse mode). This is initiated by either a +FDT or +FDR action command.

When the connect response is initiated by a +FDT command, any data sent to the modem after the connect response is sent across the phone line to the receiving fax modem. This data is a compressed bit map for the page being transmitted. It must be formatted according to the ITU-T standard T.4 (or according to the T6 standard, in the case of MMR compression). When data is sent to the modem, single DLE characters (ASCII 10h) are replaced by two DLE characters, and, for Class 2 fax only, the end of the fax page is indicated by a DLE ETX sequence (ASCII 10h followed by ASCII 03h).

When data is sent to the modem, single DLE characters (ASCII 10h) are replaced by two DLE characters, and the end of the fax page is indicated differently in different fax standards:

In Class 2, end-of-page is indicated by a DLE ETX sequence (ASCII 10h followed by ASCII 03h);

In Class 2.0 and Class 2.1, end-of-page is indicated by

DLE-EOP (ASCII 10h ASCII 2Eh)

DLE-MPS (ASCII 10h ASCII 2Ch)

DLE-EOM (ASCII 10h ASCII 3Bh)

When the connect response is initiated by a +FDR command, any data received from the modem after the connect response is data received from the transmitting fax modem. This data is a compressed bit map for the page being received, formatted according to ITU-T standard T.4 (or according to the T6 standard, in the case of MMR compression). When data is received from the modem, DLE DLE character sequences are replaced by a single DLE character. The DLE ETX character sequence indicates that the end of the fax page has been received.

The baud rate between the host and the fax modem should be at least 20 percent faster than the negotiated baud rate at which the page is transmitted between fax modems. This is because the link between the fax modems is synchronous and the link between the host and the fax modem is asynchronous. Thus, when a fax page is transmitted, fewer bits are going out of the fax modem than are coming in (8 bits per character versus 10 bits per character). If the baud rates are the same or the host-to-fax modem baud rate is less, there will be errors in the fax page, because periodically the modem will run out of data to send. Therefore, the recommended baud rate between the host and the fax modem is *at least* 38400 bps, since the fastest fax modem to fax modem baud rate is between 14400 bps and 28800 bps, with the exact rate used depending on the modem model and configuration. The same logic applies when receiving fax page data.

The baud rate is set by the speed at which the dial command is given when originating a fax call, the speed at which the answer command is given when manually answering a fax call, or the speed at which the last command is received before automatically answering the call.

Since the baud rate should be set to a minimum of 38400 bps, flow control is required on transmitting so that no data is lost. Receive flow control may be required to accommodate delays in processing the received data.

When receiving a fax in a non-error-corrected fax connection, the host should not stop the data flow for long (using the selected flow control means) lest its internal buffers overflow. The local, receiving modem has no way to stop the data from the remote modem. Therefore, if its internal buffers overflow, data loss will occur. The host must send a DC2 character (ASCII 12h) after the connect response is received before the modem will transmit the received page data to the host.

The modem can cancel a page transmission by sending a CAN character (ASCII 18h) to the host. Upon receiving the CAN character the host should send the end of page sequence (DLE-ETX) to the modem.

There are two reasons why the modem might send a cancel to the host on page transmission: First, the +FCT timeout may have occurred, which would result in a +FHS: response as the modem hung up. Second, the modem might cancel the host because it has sent enough lines for the negotiated page length. The host can also cancel page reception by sending a CAN to the modem, to which the modem will respond by sending a DLE ETX to the host and then display a +FHS: response as the modem hangs up.

If you are sending data in Class 2.0/2.1 with format conversions enabled (+FFC, see section 2.5.3.4), then you must specify the format of the data for each image parameter that is different the negotiated parameters. You must specify the data in the form of DLE sequences before the image is sent or between each image segment. The table below indicates what sequences should be sent for different image parameters. If you are using Class 2 format, this information is provided through the use of the AT+FDT command with its optional parameters.

Fax Parameter	DLE Character to Precede Image Data
fax page width, 2048 pixels	67h
fax page width, 2432 pixels	68h
fax page width, 1216 pixels	69h
fax page width, 864 pixels	6Ah
data compression, MH	6Bh
data compression, MR	6Ch
data compression, uncompressed	6Dh * not supported
data compression, MMR	6Eh
vertical resolution, standard	61h
vertical resolution, fine	62h
fax page length, A4	63h
fax page length, B4	64h
fax page length, unlimited	65h
fax page with, 1728 pixels	66h

Chapter 2 – Commands and Responses

2.1 Overview

This chapter describes three kinds of commands and responses:

- **Action commands.** Action commands initiate a sequence of events that do not execute instantaneously, and therefore change command mode to command execution mode. An action command must be the last command in a command string.
- **Responses.** Responses are result code messages sent to the host by the modem.

Note: Older MultiModem II modems, those with model numbers MT2834xx and lower, respond with the parameter name as a prefix to the value of the parameter value when a parameter value or range of values is queried.

For example: AT+FCLASS=2

Response Returned: **+FCLASS=2**

OK

The command name as prefix can be omitted by setting the +FV option to zero (see section 2.5.3.10). If the command name prefix is omitted, then the response returned would simply be 2.

- **Parameters.** Parameter commands set operating conditions. Multiple parameter commands can be sent in a command string; however, they must be separated by semicolons.

All action commands and responses are mandatory. Some parameter commands are mandatory, but others are optional. Mandatory values are specified for each command and parameter.

2.1.1 Action Commands

Class 2.1	Class 2	Action description
+FDR	+FDR	Begin or continue Phase C data reception*
+FDT	+FDT	Begin or continue Phase C data transmission
	+FET	End page or document command
+FIP		Initialize Class 2.0/2.1 parameters command
+FKS	+FK	Terminate session command—orderly fax abort

* Depends on the capability to receive set by +FCR.

2.1.2 Modem Responses

Class 2.1	Class 2	Response description
	+FCFR	Confirmation to Receive prompt
+FCO	+FCON	Facsimile connection
+FDM		Transition to data modem operation
+FVO	+FVOICE	Transition to voice operation
+FCS:	+FDCS:	Report negotiated session parameters, DCS frame information
+FIS:	+FDIS:	Report remote capabilities, DIS frame information
+FTC:	+FDTC:	Report remote capabilities, DTC frame information
+FPO	+FPOLL	Remote polling request indication
+FTI:	+FTSI:	Report remote ID, TSI
+FCI:	+FCSI:	Report remote ID, CSI
+FPI:	+FCIG:	Report remote ID, CIG

+FNF:	+FNSF:	Report received NSF frame
+FNS:	+FNSS:	Report received NSS frame
+FNC:	+FNCS:	Report received NSC frame
+FSA:		Destination subaddress
+FPA:		Selective polling address
+FPW:		Password (sending or polling)
+FFD:		File diagnostic message
+FET:	+FET:	Post page message report
+FPS:	+FPTS:	T.30 Phase C page transfer status report (post page responses)
+FHS:	+FHNG:	Call termination status
+FHR:	+FHR:	Report received HDLC frame
+FHT:	+FHT:	Report transmitted HDLC frame
+FPS:	+FPTS:	T.30 Phase C page reception
	+FV=	Prefix output on query response
+FDB:	+FDB:	Report modem debug information

2.1.3 Parameters for Mandatory Services

Class 2.1	Class 2	Mandatory parameter description
+FCLASS=	+FCLASS=	Service class selection
+FBO=	+FBOR=	Phase C data bit order (optional parameter in Class 2)
+FCC=	+FDCC=	Set modem capabilities
+FCQ=	+FCQ=	Copy quality checking (optional parameter in Class 2)*
+FIS=	+FDIS=	Set current session capabilities
+FCS?	+FDCS?	Current session results (read only)
+FEA=	+FREL=	Phase C Received EOL alignment (optional parameter in Class 2)*
+FLI=	+FLID=	Local fax station ID string, TSI or CSI
+FPI=	+FCIG=	Local fax station polling ID string, CIG
+FSP=	+FSPL=	Request to poll*
+FLP=	+FLPL=	Indicate document to poll
+FPS=	+FPTS=	Page transfer status*
+FFD=		File diagnostic message
+FHS?		Call termination status
+FIE=		Procedure interrupt enable
+FIT=		host inactivity timer
+FNR=		Negotiation message reporting control
+FPA=		Selective polling address
+FSA=		Subaddress
+FPP=		Packet protocol control
+FPW=		Password (sending or polling)
+FLO=	+FLO=	Set local flow control
+FPR=		Set local port rate
+FMI?	+FMFR?	Request modem manufacturer
+FMM?	+FMDL?	Request modem model
+FMR?	+FREV?	Request modem revision

* Depends on the capability to receive set by +FCR.

2.1.4 Parameters for Optional Services

Class 2.1	Class 2	Optional parameter description
+FAA=	+FAA=	Adaptive answer mode
+FAP=		Addressing & polling capabilities
	+FBADLIN=	Number of consecutive bad lines for a bad page
	+FBADMUL=	Error threshold multiplier
+FBS?	+FBUF?	Buffer size, read only
+FBU=	+FBUG=	HDLC frame reporting enable
+FCR=	+FCR=	Capability to receive
+FCT=	+FPHCTO=	Host Phase C timeout
+FDB=	+FDB=	Enable fax debug responses
+FDD=	+FDD=	Enable extended +FHT/+FHR responses
+FFC=	+FDFFC=	Data compression format conversion
	+FLNFC=	Page length format conversion
	+FVRFC=	Vertical resolution format conversion
	+FWDFC=	Page width format conversion
+FMS=	+FMINSP=	Minimum Phase C speed
+FND=		Non-standard message data indication
+FNS=		Non-standard frame FIF
+FRQ=		Receive quality thresholds
+FSn	+FSn	Modify Fax S-Register
+FRY=	+FCTCRTY	CTC/ECM retry value
	+FAXERR=	Fax error value
	+FRBOR	Set receive Bit Order to Rockwell/Lucent order. *
	+FV	Display prefix on parameter queries. *
		* Applicable to Multi-Tech MT28xx models and earlier (which includes MT24xx, MT19xx, MT14xx).

2.2 Identification Commands

2.2.1 Service Class Indication

A MultiModem modem will report its Service Class capabilities, both the current setting and the range of services available. This is provided by the +FCLASS parameter. Currently-defined values for the +FCLASS parameter are:

Parameter	Service Class
0	Data modem
1	Fax Service Class 1 (TIA-578, ITU-T.31)
1.0	Fax Service Class 1.0 (ITU-T T.31, Amendment 1)
2	Fax Service Class 2 (EIA 29.2)
2.0	Fax Service Class 2.0 (ITU-T T.32)
2.1	Fax Service Class 2.1 (ITU-T T.32 Amendment 1)
3-7	Reserved (not supported)
8	Voice modem
9-255	Reserved (not supported)
[None]	Not supported

The +FCLASS factory default setting is +FCLASS=0. When +FCLASS is set to other than 0 and a call is made, but the call fails or the modem is disconnected, the +FCLASS value returns to the default setting (+FCLASS=0).

Class 2.1 +FCLASS?

T.32 reference: 8.2.1

A modem's current Service Class setting is tested by the +FCLASS? command. The response is a single value.

Class 2 FCLASS?

Same as Class 2.1.

2.2.2 Service Class Capabilities

Class 2.1 +FCLASS=?

T.32 reference: 8.2.2

The Service Classes available from a modem are tested by the +FCLASS=? command. The response is a string of values separated by commas. A Class 2.1 MultiModem can respond:

EXAMPLE: <CR><LF>0,1,2,1.0,2.0,2.1,8<CR><LF>OK<CR><LF>.

Class 2 +FCLASS=?

A Class 2 MultiModem responds similarly; however, older Multi-Tech modems that do not support Class 2.1 report fewer options.

2.2.3 Service Class Selection

Class 2.1 +FCLASS=<value>

T.32 reference: 8.2.3

The Service Class may be set by the host from the above choices using the +FCLASS=<value> command. Once the result code is received from the modem.

Class 2 +FCLASS=<value>

Same as Class 2, except for the +FPR command. In Class 2, the serial port rate is set by the speed at which the dial command is given when originating a fax call, the speed at which the answer command is given when manually answering a fax call, or the speed at which the last command is received before automatically answering the call.

2.2.4 Request Manufacturer Identification

Class 2.1 +FMI?

T.32 reference: Table A.1

The +FMI? command executes the V.25ter +GMI? command to request the name of the modem's manufacturer.

EXAMPLE: AT+FMI?
Multi-Tech Systems
OK

Class 2 +FMFR?

The +FMFR? command requests the name of the modem's manufacturer.

2.2.5 Request Model Identification

Class 2.1 +FMM?

T.32 reference: Table A.1

The +FMM? command executes the V.25ter +GMM? command to request the modem's model number.

EXAMPLE: AT+FMM?
MT5634ZBA-V92
OK

Class 2 +FMDL?

The +FMDL? command requests the modem's model number.

2.2.6 Request Revision Identification

Class 2.1 +FMR?

T.32 reference: Table A.1

The +FMR? command executes the V.25ter +GMR? command to request the modem's firmware revision number.

EXAMPLE: AT+FMI?

OK

Class 2 +FREV?

The +FREV? command requests the modem's model number.

2.3 Action Commands

Action commands transfer data and punctuate sessions. They also release specific T.30 messages.

An action command with a terminating carriage return character, <CR>, in the syntax specification must be the last command on a command line. Subsequent commands on the same line as one of these action commands will be ignored.

All action commands initiate processes. The modem does not accept other commands from the host until the modem issues a final result code (e.g. *OK*, *CONNECT*). The modem will abort the process if it receives any character before the final result code is issued other than an immediate <LF> character, flow control characters (<DC1> or <DC3>), or other characters defined for that command.

2.3.1 Originate a Call

Class 2.1 ATD

Syntax: ATD[<dial string>]<CR> or
ATD[<dial string>];<valid commands><CR>

T.32 reference: 8.3.1

All Multi-Tech MultiModems support the D command to originate a call. This Originate command is documented in the MultiModem *User Guide*.

On legacy modems only (MT28xx models and earlier, which includes MT24xx, MT19xx, MT14xx), the host may issue a D command to initiate a call or to resume a session after procedure interruption.

For both legacy and current modems, if the D command is unsuccessful, the MultiModem reports an appropriate failure or error type result code and terminates the call.

Class 2 ATD

Same as Class 2.1.

2.3.2 Answer a Call

Class 2.1 ATA

Syntax: ATA <CR>
T.32 reference: 8.3.2

The Answer command is documented in the MultiModem User Guide.

On legacy modems only (MT28xx models and earlier, which includes MT24xx, MT19xx, MT14xx), the host may issue an Answer command to resume a session after procedure interruption. For all MTS modems, the host may issue an Answer command in response to rings.

If the Answer command is unsuccessful, the MultiModem reports an appropriate failure or error type result code, such as *NO CARRIER*.

If configured to do so by the +FAA parameter, the modem may adaptively answer as a fax modem or as a data modem. If the modem answers as a data modem, it resets the +FCLASS parameter to 0, and issues appropriate final result codes (e.g. *CONNECT*, *NO CARRIER*) to the host.

Class 2 ATA

Same as Class 2.1.

2.3.3 Data Transmission

Class 2.1 +FDT

Syntax: +FDT<CR>
T.32 reference: 8.3.3

The FDT command requests the modem to transmit a Phase C page. It is issued at the beginning of each page, either in Phase B or in Phase D. When the modem is ready to accept Phase C data, it issues the negotiation responses and the *CONNECT* result code to the host. Negotiation responses are controlled by the +FNR subparameters.

In Phase B, the +FDT command releases the modem to proceed with negotiation, and to release the DCS message to the remote station. In Phase D, the +FDT command resumes transmission after the end of a previous page.

Class 2 +FDT

Syntax: +FDT[=DF,VR,WD,LN]<CR>

On legacy modems only (MT28xx models and earlier, which includes MT24xx, MT19xx, MT14xx), the T.30 DF, VR, WD and LN subparameters are optional. This specifies the form of the data to follow after the *CONNECT* is issued. This command will be supported once again in forthcoming "ZBA" models.

2.3.4 Post-Page Message Release

Class 2 +FET=n

This command releases the post-page message to the remote modem. The possible values for *n* are listed in the table below.

n =	Symbol	Description
0	MPS	Multi-Page Signal
1	EOM	End of Message
2	EOP	End of Page
4*	PRI-MPS	Multi-Page Signal, with procedure interrupt
5*	PRI-EOM	End of Message, with procedure interrupt
6*	PRI-EOP	End of Procedure, with procedure interrupt
* Used in legacy modems only (MT28xx models and earlier, which includes MT24xx, MT19xx, MT14xx).		

2.3.5 Data Reception

Class 2.1 +FDR

Syntax: +FDR<CR>
T.32 reference: 8.3.4

The +FDR command initiates transition to Phase C data reception. This can occur after answering, after dialing, after a document is received, or after a page is received.

The modem may report the negotiated T.30 parameters with the remote ID and NSS frame information, if available. When the modem is ready to commence data transfer, it will issue a *CONNECT* response code. After the host receives the *CONNECT* response and the host is ready to accept data, it will issue a <DC2> character (12h) to the modem.

Class 2 +FDR

Same as Class 2.1.

2.3.6 Session Termination

Class 2.1 +FKS

Syntax: +FKS
T.32 reference: 8.3.5

The +FKS command causes the modem to terminate the session in an orderly manner by sending a DCN message at the next opportunity and hanging up. At the end of the termination process, the modem will report the +FHS response with a result code, go on-hook, and set +FCLASS=0.

This operation can also be invoked by using the <CAN> (cancel) character during Phase C data reception.

Class 2 +FK

Syntax: +FK
Essentially the same as Class 2.1.

2.3.7 Initialize Facsimile Parameters

Class 2.1 +FIP

Syntax: +FIP

T.32 reference: 8.3.6

The +FIP command causes the modem to initialize all Service Class 2.0/2.1 facsimile parameters to the default settings. This command does not change the setting of +FCLASS. It has the same effect as if the host had issued individual parameter setting commands.

MultiModem modems do not support multiple profiles, and thus do not support the optional +FIP=<value> syntax documented in T.32.

Class 2 There is no equivalent command in Class 2.

2.4 Modem Responses

The modem sends information responses to the host as a facsimile session proceeds. Responses convey needed information and indicate the state of the facsimile session. These responses are solicited messages, generated in execution of host action commands described in section 2.3.

The modem precedes all of the following information responses with <CR><LF>, and follows them with <CR><LF> if in verbose mode (ATV1) or follows them with just a <CR> if in terse mode (ATV0).

2.4.1 T.30 Phase A Negotiation Responses

2.4.1.1 Facsimile Connection Response

Class 2.1 +FCO

Syntax: +FCO

T.32 reference: 8.4.1.1

The +FCO response indicates connection with a Group 3 facsimile station. It is released by detection of HDLC flags in the first received frame. +FCO is generated in response to an Originate command (2.3.1) or an Answer command (2.3.2).

Class 2 +FCON

Syntax: +FCON

The Class 2 response is essentially the same as the Class 2.1 response.

2.4.1.2 Transition to Data Modem; FDM

Class 2.1 +FDM

Syntax: +FDM

T.32 reference: 8.4.1.2

The +FDM response indicates that the modem has identified that the calling device is a data modem. The modem issues this response immediately upon recognition of a data modem. The +FDM response precedes any data modem information text or result codes.

Class 2 There is no equivalent response in Class 2.

2.4.2 T.30 Phase B Negotiation Responses

The modem will provide the on-line status of several session parameters when they are available in the T.30 handshaking and if enabled via the +FNR subparameters. These include the remote ID string and the DIS/DCS/DTC parameters.

2.4.2.1 Report DIS/DCS/DTC Frame Information

Class 2.1 +FCS:, +FIS:, +FTC:

Syntax: +FCS:VR,BR,WD,LN,DF,EC,BF,ST,JP Current Session

Syntax: +FIS:VR,BR,WD,LN,DF,EC,BF,ST,JP Remote Identification

Syntax: +FTC:VR,BR,WD,LN,DF,EC,BF,ST,JP Request for Polling

T.32 reference: 8.4.2.1

These responses report the T.30 session parameter frames.

+FCS:<string> reports the negotiated parameters. Phase C data will be formatted as described by the subparameters. This message may be generated in execution of +FDT or +FDR commands before the *CONNECT* result code if new DCS frames are generated or received.

+FIS:<string> and +FTC:<string> report remote facsimile station capabilities and intentions. If the remote has a document to poll, a +FPO response will trail +FIS:<string>; if the remote station wants to poll, the +FTC:<string> response is generated. These messages are generated in execution of Originate, Answer, +FDT and +FDR commands.

Class 2 +FDCS:, +FDIS: +FDTC:

Syntax: +FDCS:VR,BR,WD,LN,DF,EC,BF,ST Current Session

Syntax: +FDIS:VR,BR,WD,LN,DF,EC,BF,ST Remote Identification

Syntax: +FDTC:VR,BR,WD,LN,DF,EC,BF,ST Request for Polling

The Class 2 responses are essentially the same as the Class 2.1 responses, except that Class 2 lacks the JP subparameter, and the sets of values supported for each subparameter is a subset of class 2.1 values.

2.4.2.2 Remote Polling Indication

Class 2.1 +FPO

Syntax: +FPO

T.32 reference: 8.4.2.2

The +FPO response indicates that the remote station has a document to poll and invites the host to poll it. This response is generated in execution of Originate), Answer), +FDT) and +FDR) commands. +FSP=0 inhibits the +FPO response (2.5.1.9). The host may respond to an +FPO message with either the begin transmit command, AT+FDT, if it does not wish to poll, or the +FDR command to indicate willingness to poll the remote station.

Class 2 +FPOLL

Syntax: +FPOLL

The Class 2 response is essentially the same as the Class 2.1 response.

2.4.2.3 Report Remote ID

Class 2.1 +FTI:, +FCI:, +FPI:

Syntax: +FTI:"<TSI ID string>" Transmit Station ID

Syntax: +FCI:"<CSI ID string>" Called Station ID

Syntax: +FPI:"<CIG ID string>" Polling Station ID

T.32 reference: 8.4.2.3

These responses report the received remote ID string, if any. They are generated in execution of the Originate, Answer, +FDT, and +FDR commands.

The modem reports the characters in the ID string in reversed time order from the order received from the remote station. For example, if the following ID FIF character string were received (hexadecimal values):

```
<20><20><20><20><20><31><30><39><38><20><37><36><35><20><34><33><32><20><31><2B>
```

The result would be:

```
<CR><LF>+FCI:"+1 234 567 8901 " <CR><LF>
```

Class 2 +FTSI:, +FCSI:, +FCIG:

Syntax: +FTSI:"<TSI ID string>" Transmit Station ID

Syntax: +FCSI:"<CSI ID string>" Called Station ID

Syntax: +FCIG:"<CIG ID string>" Polling Station ID

The Class 2 responses are essentially the same as the Class 2.1 responses.

2.4.2.4 Report Non-Standard Negotiation Frames

Class 2.1 +FNF:, +FNS:, +FNC:

Syntax: +FNF:<NSF FIF string> Non-Standard Facilities
 Syntax: +FNS:<NSS FIF string> Non-Standard Setup
 Syntax: +FNC:<NSC FIF string> Non-Standard Commands
 T.32 reference: 8.4.2.4

These responses report received non-standard negotiation frames, one response per frame. These responses are generated in execution of the Originate, Answer, +FDT, and +FDR commands.

The NSF Facsimile Information Field (FIF) frame octets are presented in hex notation, and are separated by spaces. Flags and zero bits are removed. Frame octets are reported in the order received. For each frame octet the LSB is the first bit sent or received.

Class 2 +FNSF:, +FNSS:, +FNCS:

Syntax: +FNSF:<NSF FIF string> Non-Standard Facilities
 Syntax: +FNSS:<NSS FIF string> Non-Standard Setup
 Syntax: +FNCS:<NSC FIF string> Non-Standard Commands

The Class 2 responses are essentially the same as the Class 2.1 responses.

2.4.2.5 Report Addressing or Password strings

Class 2.1 +FSA:, +FPA:, +FPW:

Syntax: +FSA:"<SUB string>" Destination Subaddress
 Syntax: +FPA:"<SEP string>" Polling Address
 Syntax: +FPW:"<PWD string>" Polling Password
 T.32 reference: 8.4.2.5

These responses report the received Addressing or Password string, if any. Originate, Answer, +FDT or +FDR command execution may generate these responses, if the corresponding frames are received.

If the corresponding subparameter in the +FAP parameter is set, the modem shall report the characters in these strings in reversed time order from the order received from the remote station. For example, if the following hexadecimal Subaddress string is received:

```
<39><38><37><36><35><34><33><32><31><30><39><38><37><36><35><34><33><32><31><30>
```

The result would be:

```
<CR><LF>+FCI:"01234567890123456789"<CR><LF>
```

Class 2 There are no equivalent responses in Class 2.

2.4.3 T.30 Phase C Page Reception Responses

2.4.3.1 Receive Page Transfer Status

Class 2.1 +FPS:

Syntax: +FPS:<ppr>,<lc>,<bic>,<cbic>,<lbc>

T.32 reference: 8.4.3

The +FPS:<ppr> response is generated by the modem at the end of Phase C data reception in execution of a +FDR command.

The <ppr> response is generated by the modem; it depends on the modem for T.4 or T.6 error checking capabilities, controlled by the +FCQ parameter.

The receiving modem may count lines and bad lines, and report them. These values are:

<lc>	line count
<bic>	bad line count
<cbic>	consecutive bad line count
<lbc>	lost byte count due to modem buffer overflow

The line counts are qualified by the modem's copy checking capabilities, controlled by the +FCQ parameter. If the modem is not configured to count lines, or if line counts are irrelevant (e.g. in Binary File Transfer mode, Recommendation T.434) the modem sets the line counts to 0.

A receiving host may inspect <ppr> and write a modified value into the +FPS parameter. The modem will hold the corresponding post page response message until released by a +FDR command from the host.

Table 2.2.0 Class 2.1 T.30 Post Page Response Message Codes

Value	Mnemonic	Description
1	MCF	Page good.
2	RTN	Page bad; retrain requested.
3	RTP	Page good; retrain requested.
4	PIN	Page bad; retrain requested; interrupt request accepted.
5	PIP	Page good; interrupt request accepted.

Class 2 +FPTS:

Syntax: +FPTS:<ppr>,<lc>[,<bic>,<cbic>][,<lbc>]

The Class 2 response is similar to the Class 2.1 response, except that it may also use <ppr> codes 0, 6, and 7, which are not used in the Class 2.1 response.

Table 2.2.1 Class 2 T.30 Post Page Response Message Codes

Value	Mnemonic	Description
0	PPR	Partial page errors.
1	MCF	Page good.
2	RTN	Page bad; retrain requested.
3	RTP	Page good; retrain requested.
4*	PIN	Page bad; retrain requested; interrupt request accepted.
5*	PIP	Page good; interrupt request accepted.
* Used in legacy modems only (MT28xx models and earlier, which includes MT24xx, MT19xx, MT14xx).		

2.4.4 T.30 Phase D Post Page Responses

2.4.4.1 Post Page Message

Class 2.1 +FET:

Syntax: +FET:<ppm>

T.32 reference: 8.4.4.1

The +FET:<post page message> response is generated by a receiving facsimile modem at the end of Phase C reception on receipt of the post-page message from the transmitting station. The +FET:<ppm> response is generated in execution of a +FDR command. The <ppm> codes correspond to the T.30 post page messages as described in Table 2.1.0.

Table 2.1.0. Class 2.1 Post Page Message Codes

PPM code	T.30 mnemonic	Description
0	MPS	Another page next, same document
1	EOM	Another document next
2	EOP	No more pages or documents
*3	PRI-MPS	Another page, procedure interrupt
*4	PRI-EOM	Another document, procedure interrupt
*5	PRI-EOP	All done, procedure interrupt
* Used in legacy modems only (MT28xx models and earlier, which includes MT24xx, MT19xx, MT14xx).		

Class 2 +FET:

Syntax: +FET:<ppm>

Class 2 reference: 2.4.4.1

The Class 2 response is similar to the Class 2.1 response, except for the different <ppm> codes described in Table 2.1.1.

Table 2.1.1. Class 2 Post Page Message Codes

PPM code	T.30 mnemonic	Description
0	MPS	Another page next, same document
1	EOM	Another document next
2	EOP	No more pages or documents
3	PPS-NULL	Another partial page next
4	PRI-MPS	Another page, procedure interrupt
5	PRI-EOM	Another document, procedure interrupt
6	PRI-EOP	All done, procedure interrupt

2.4.4.2 Transition to Voice (legacy modems only)

Class 2 +FVOICE

Syntax: +FVOICE

+FVO indicates that a procedure interruption has been negotiated, and the session has been suspended. This response is generated in execution of the +FET=<PRI-Q> or +FPS=<PIP/PIN> and +FDR commands.

The host responds to a +FVO message by suspending the session, and waits for the operator to determine if the session should be resumed or terminated.

The Class 2 response is essentially the same as the Class 2.1 response.

2.4.5 Call Termination with Status

Class 2.1 +FHS:

Syntax: +FHS:<hangup status code>

T.32 reference: 8.4.5

+FHS: indicates that the call has been terminated. The hangup cause is reported, and stored in the +FHS parameter for later inspection. The <hsc> values are hexadecimal codes as described in Table 2.3.

+FHS:<hsc> is a possible intermediate result code to any host action command described in section 2.3. It is always followed by the OK result code.

Class 2 +FHNG:

Syntax: +FHNG:<hangup status code>

Class 2 reference: 2.4.5

The Class 2 response is the same as the Class 2.1 response except that the hangup cause is stored in the +FAXERR parameter and the <hsc> values are decimal codes as described in Table 2.3.

Table 2.3. Hangup Status Codes

Class 2.1	Class 2	Cause
00–0F	0–9	Call placement and termination:
00	0	Normal and proper end of connection
01	1	Ring detect without successful handshake
02	2	Call aborted from +FKS [FK] or <CAN>
03	3	No Loop Current
04	-	Ringback detected, no answer (timeout)
05	-	Ringback detected, answer without CED
10–1F	10–19	Transmit Phase A & miscellaneous errors
10	10	Unspecified Phase A error
11	11	No Answer (T.30 T1 timeout)
20–3F	20–39	Transmit Phase B hangup codes
20	20	Unspecified transmit Phase B error
21	21	Remote cannot receive or send
22	22	COMREC error in transmit Phase B
23	23	COMREC invalid command received
24	24	RSPEC error
25	25	DCS sent three times without response
26	26	DIS/DTC received 3 times; DCS not recognized
27	27	Failure to train at 2400 bps or +FMS [+FMINS] value
28	28	RSPREC invalid response received
40–4F	40–49	Transmit Phase C hangup codes
40	40	Unspecified transmit Phase C error
41	-	Unspecified image format error
42	-	Image conversion error
43	43	host to modem data underflow
44	-	Unrecognized transparent data command

Class 2.1	Class 2	Cause
45	-	Image error, line length wrong
46	-	Image error, page length wrong
47	-	Image error, wrong compression code
50–6F	50–69	Transmit Phase D hangup codes
50	50	Unspecified transmit Phase D error
51	51	RSPREC error
52	52	No response to MPS repeated 3 times
53	53	Invalid response to MPS
54	54	No response to EOP repeated 3 times
55	55	Invalid response to EOP
56	56	No response to EOM repeated 3 times
57	57	Invalid response to EOM
58	58	Unable to continue after PIN or PIP
70–8F	70–89	Receive Phase B hangup codes
70	70	Unspecified receive Phase B error
71	71	RSPREC error
72	72	COMREC error
73	73	T.30 T2 timeout, expected page not received
74	74	T.30 T1 timeout after EOM received
90–9F	90–99	Receive Phase C hangup codes
90	90	Unspecified receive Phase C error
91	91	Missing EOL after 5 seconds (section 3.2/T.4)
92	-	Bad CRC or frame (ECM mode)
93	93	modem to host buffer overflow
-	94	Bad CRC or frame (ECM or BFT mode)
A0–BF	100–119	Receive Phase D hangup codes
A0	100	Unspecified receive Phase D errors
A1	101	RSPREC invalid response received
A2	102	COMREC invalid response received
A3	103	Unable to continue after PIN or PIP
C0–DF	120–255	Reserved for future standardization
E0–FF	-	Reserved for manufacturer-specific use

2.5 Parameter Commands

All Class 2 parameters can be read, written, and tested for the range of legal values by the modem. The general syntax is described in section 1.3.1 of this manual.

2.5.1 T.30 Session Parameters

Group 3 fax devices negotiate session parameters in the DIS, DCS and DTC frames. The following parameters are provided to condition the fax modem for the capabilities it will offer, and to report the negotiated session settings.

The three primary T.30 session parameters are +FCC [FDCC], +FIS [FDIS] and +FCS [FDCS], described in 2.5.1.1–2.5.1.3. These are compound parameters using values listed in Table 2.4. Figure 2.5.1 illustrates their relationships:

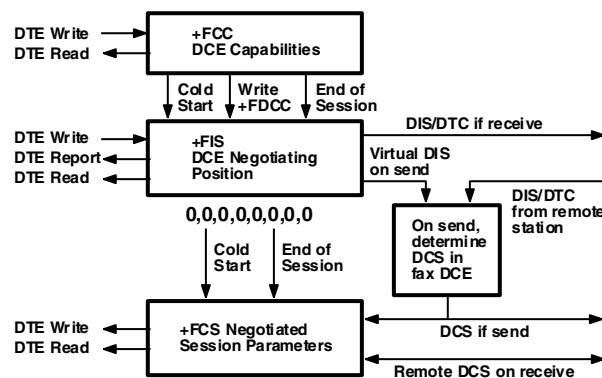

Figure 2.5.1. T.30 session parameters

2.5.1.1 Modem Capabilities Parameters

Class 2.1 +FCC=

Write syntax: +FCC=VR,BR,WD,LN,DF,EC,BF,ST,JP

Valid values: See Table 2.4

Default values: 1,5,0,2,0,0,0,0

T.32 reference: 8.5.1.1

+FCC allows the host to sense and constrain the capabilities of the facsimile modem, from the choices defined in ITU-T T.30 Table 2. When +FCC is modified by the host, the modem will copy +FCC into +FIS.

Note. The Multi-Tech implementation does not include the T.32 subparameter WD 3 and 4 values or the EC 2 and 3 values; also, for subparameter BF only the 00 value is implemented.

Class 2 +FDCC=

Write syntax: +FCC=VR,BR,WD,LN,DF,EC,BF,ST

Valid values: See Table 2.4.

Default values: 1,5,0,2,0,0,0,0***

Class 2 reference: 2.5.1.1

The Class 2 parameter is essentially the same as the Class 2.1 parameter except that it lacks the JP subparameter, and the modem copies +FDCC into +FDIS.

2.5.1.2 Current Sessions parameters

Class 2.1 +FIS=

Write syntax: +FIS=VR,BR,WD,LN,DF,EC,BF,ST,JP

Valid values: See Table 2.4

Default values: 1,3,2,2,0,0,0,0,0

T.32 reference: 8.5.1.2

The +FIS parameter allows the host to sense and constrain the capabilities used for the current session. The modem uses +FIS to generate DIS or DTC messages directly, and uses +FIS and received DIS messages to generate DCS messages.

The modem sets the +FIS parameter from the +FCC parameter on initialization, when +FCC is written, and at the end of a session.

Class 2 +FDIS=

Write syntax: +FCC=VR,BR,WD,LN,DF,EC,BF,ST

Valid values: See Table 2.4

Default values: 1,3,2,2,0,0,0,0***

Class 2 reference: 2.5.1.2

The Class 2 parameter is essentially the same as the Class 2.1 parameter except that it lacks the JP subparameter, and the +FDIS parameter is set from the +FDCC parameter.

2.5.1.3 Current Session Results

Class 2.1 +FCS?

Read syntax: +FCS?

Modem response: VR,BR,WD,LN,DF,EC,BF,ST,JP

Valid values: See Table 2.4

Default values: 0,0,0,0,0,0,0,0,0

T.32 reference: 8.5.1.3

The +FCS parameter is loaded with the negotiated T.30 parameters for the current session. A transmitting modem generates DCS; a receiving modem gets DCS from the remote station. The host may only read this parameter.

The +FCS parameter is set to 0,0,0,0,0,0,0,0 on initialization, on +FIP command execution, and at the beginning of a session. If the host issues a +FCS? command in the initial state, the modem will report:

```
<CR><LF>0,0,0,0,0,0,0,0,0<CR><LF>
```

The contents of +FCS are spontaneously reported during execution of +FDR (2.3.5) or +FDT (2.3.3) commands by the +FCS: VR,BR,WD,LN,DF,EC,BF,ST,JP response, using the same compound parameter format. See section 2.4.2.1.

Class 2 +FDCS?

Read syntax: +FDCS?

Modem response: +FDCS=VR,BR,WD,LN,DF,EC,BF,ST

or: +FDCS=

Valid values: See Table 2.4

Default values: 0,0,0,0,0,0,0,0,0

Class 2 reference: 2.5.1.3

The Class 2 parameter is essentially the same as the Class 2.1 parameter except that the response lacks the JP subparameter.

2.5.1.4 T.30 session subparameters

Several commands and responses reference T.30 session negotiated parameters. These are described by a set of common subparameters, which are described in Table 2.4. Optional parameter values are marked with an asterisk (*). Unspecified parameter values are reserved for future use.

The +FCC [+FDCC], +FIS [+FDIS], and +FCS [+FDCS] compound parameters, described in sections 2.5.1.1–3, use these session subparameters. On writes, unspecified subparameters are unchanged.

The +FIS: [+FDIS:], +FCS: [+FDCS:], and +FTC: [+FDTC:] session report responses, described in section 2.4.2.1, also use these subparameters.

In Class 2, some subparameters are optionally used in the +FDT[=*DF,VR,WD,LM*] command (which is supported in legacy modems only: in MT28xx models and earlier, which includes MT24xx, MT19xx, MT14xx), as described in section 2.3.3. In Class 2.0, formats are specified using DLE sequences preceding image data.

For test response, ranges of values are reported for each subparameter, enclosed in parentheses characters. For example, a modem response to +FCC=? [+FDCC=?] could report:

```
<CRLF>(0-1),(0-3),(0-4),(0-2),(0),(0),(0),(0-7),(0)<CRLF>
```

Example: +FIS=0,3,0,2,0,0,0,1,0 is interpreted as follows:

Value	Label	Description
0	VR	98 dpi vertical resolution
3	BR	9600 bit/s
0	WD	1728 pixels
2	LN	unlimited length
0	DF	1-D modified Huffman coding
0	EC	no ECM
0	BF	no BFT
1	ST	5 ms scan time
0	JP	no JPEG

Note: The data type sent using the Class 2+FDT[=*DF,VR,WD,LM*] command (which is supported in legacy modems only: in MT28xx models and earlier, which includes MT24xx, MT19xx, MT14xx) may be different if conditioned by optional data conversion services (available only on certain modem models). This is used to concatenate dissimilar files.

Table 2.4. T.30 Session Subparameter Codes

Label	Function	Class 2.0/2.1 (hexa-decimal values)	Class 2 (decimal values)	Description	
VR	Vertical resolution (Note 1)	00h 01h *02h *04h *08h *10h *20h *40h *†80h *†100h *†200h *†400h *†800h * Class 2.1 only † Not available on all models	0 1	R8 x 3.85 lines/mm, (98 dpi) Normal R8 x 7.7 lines/mm, (196 dpi) Fine R8 x 15.4 lines/mm R16 x 15.4 lines/mm 200 dpi x 100 lines/25.4 mm 200 dpi x 200 lines/25.4 mm 400 dpi x 400 lines/25.4 mm 300 dpi x 300 lines/25.4 mm 300 dpi x 600 lines/25.4 mm 600 dpi x 600 lines/25.4 mm 1200 dpi x 600 lines/25.4 mm 1200 dpi x 1200 lines/25.4 mm 400 dpi x 800 lines/25.4 mm	
BR	Bit rate (Note 2)	0h 1h 2h 3h 4h 5h	0 1 2 3	+FCC/+FIS description 2 400 bit/s preferred 4 800 bit/s preferred 7 200 bit/s preferred 9 600 bit/s preferred 12 000 bit/s preferred 14 400 bit/s preferred all with V.8 optional	+FCS description 2 400 bit/s selected 4 800 bit/s selected 7 200 bit/s selected 9 600 bit/s selected 12 000 bit/s selected 14 400 bit/s selected
		V.34 bit rate (Class 2.1 only)	6h 7h 8h 9h Ah Bh Ch Dh Class 2.1 only		16 800 bit/s preferred 19 200 bit/s preferred 21 600 bit/s preferred 24 000 bit/s preferred 26 400 bit/s preferred 28 800 bit/s preferred 31 200 bit/s preferred 33 600 bit/s preferred all with V.8 implied
		Eh		Reserved	Reserved
WD	Page width in pixels	0h 1h 2h 3h 4h	0 1 2 3 4	R8 R16 200 300 400 d/mm d/mm dpi dpi dpi 1728 3456 1728 2592 3456 2048 4096 2048 2432 4864 2432 1216 2432 supported on legacy products only 864 1728 supported on legacy products only	
				Legacy modems are MT28xx models and earlier, which includes MT24xx, MT19xx, MT14xx.	
LN	Page length	0h 1h 2h	0 1 2	A4, 297 mm B4, 364 mm Unlimited length	
DF	Data compression format	0h 1h 3h *†4h *†8h * Class 2.1 only † Not available on all models	0 1	1-D modified Huffman (T.4) 2-D modified read (T.4) 2-D modified read (T.6) JBIG (T.82) JBIG-L0 (T.82)	

Label	Function	Class 2.0/2.1 (hexa-decimal values)	Class 2 (decimal values)	Description	
EC	Error correction, T.30	0h	0	Disable ECM	
		1h	2	64-byte frames, Annex A/T.30 256-byte frames, Annex A/T.30	
BF	Binary file transfer	00h	0	Disable file transfer modes	
ST	Scan time/line	0h	0	VR = 0	VR > 0
		1h	1	0 ms	0 ms
		2h	2	5 ms	5 ms
		3h	3	10 ms	5 ms
		4h	4	10 ms	10 ms
		5h	5	20 ms	10 ms
		6h	6	20 ms	20 ms
		7h	7	40 ms	20 ms
JP	JPEG for color and B&W (Note 2)	00		Disable JPEG coding	
		01		Enable JPEG coding (T.81)	
		02		Full color mode	
		04		Enable preferred Huffman tables (Note 3)	
		08		12 bits/pel/component	
		10		No subsampling (1:1:1)	
		20		Custom illuminant	
		40		Custom gamut range	

Notes

- For subparameter VR, values 00, 01, 02, 04, 08, 10, 20 and 40 (hexadecimal) indicate a single choice; they are the only values allowed in the +FCS parameter and +FCS: report. All values that are sums of these values shall only be used to indicate multiple capabilities; these are allowed in +FIS and +FCC parameters. For example, value 07 (01 + 02 + 04) would indicate capability for all metric-based resolutions.
- For subparameter JP, values 00, 01, 02, 04, 08, 10, 20 and 40 (hexadecimal) indicate a single choice. All values that are sums of these values shall only be used to indicate multiple capabilities in +FIS and +FCC subparameters and to indicate the choice in the +FCS subparameter. For example, to indicate support for JPEG, full color mode, and no subsampling, the host should set the JP subparameter to 01 + 02 + 10 = 13h. If one or several of the values 02h to 40h are not used, that means that the default value for the subparameter (e.g. respectively: gray-scale, custom Huffman tables, 8 bit/pel/component, 4:1:1 subsampling ratio, D50 illuminant, default gamut range) is used, as defined in Annex E/T.30 and Annex G/T.4.
- The modem ignores this value in +FCC and in +FIS when generating DIS or DTC frames.

2.5.1.5 Local ID string

Class 2.1 +FLI

Write syntax: +FLI="<local ID string>"
 Valid values: 20-character printable ASCII string
 Mandatory values: 20 character string, Table 3/T.30
 Default value: null string
 T.32 reference: 8.5.1.5

The modem generates a TSI or CSI frame if FLI is not a null string. Table 3/T.30 includes digits 0–9, the + character, and the space character.

The modem transmits ID string characters to the remote station in reversed time order from the order in the command line. For example, if the command line

AT+FLI="+1 234 567 8901"<CR>

is issued, the modem would send a CSI or TSI frame with FIF (hexadecimal) consisting of
 <20><20><20><20><20><31><30><39><38><20><37><36><35><20><34><33><32><20><31><2B>

If less than 20 characters are specified in a non-null string, the modem appends space characters (<20>). If the specified string is more than 20 characters in length, an ERROR result code is generated.

Class 2 +FLID

Write syntax: +FLID="<local ID string>"
 Valid values: 20-character printable ASCII string
 Mandatory values: 20 character string, Table 3/T.30
 Default value: null string
 Class 2 reference: 2.5.1.5

The Class 2 parameter is essentially the same as the Class 2.1 parameter.

2.5.1.6 Local Polling ID string

Class 2.1 +FPI

Write syntax: +FPI="<local polling ID string>"
 Valid values: 20-character printable ASCII string
 Mandatory values: 20 character string, Table 3/T.30
 Default value: null string
 T.32 reference: 8.5.1.5

The modem generates a CIG frame if FPI is not a null string. CIG is used in polling sessions. Table 3/T.30 includes digits 0–9, the + character, and the space character.

Like the +FLID command, the modem transmits ID string characters to the remote station in reversed order from the order in the command line.

Class 2 +FCIG

Write syntax: +FCIG="<local ID string>"
 Valid values: 20-character printable ASCII string
 Mandatory values: 20 character string, Table 3/T.30
 Default value: null string
 Class 2 reference: 2.5.1.6

The Class 2 parameter is essentially the same as the Class 2.1 parameter.

2.5.1.7 Non-Standard Frame FIF Octet String

Class 2.1 +FNS

Write syntax: +FNS="<hexadecimal-coded octet string>"

Valid values: up to 90 octets

Default value: null string

T.32 reference: 8.5.1.6

If +FNS is not a null string, the modem sends the corresponding non-standard facilities frame. The type of frame is determined by the type of negotiation frame to be sent: NSF sent with DIS; NSS sent with DCS; NSC sent with DTC.

The modem only delivers the data; the host must determine the content. The first octet must be the country code (see Recommendation T.35).

Class 2 There is no equivalent parameter in Class 2.

2.5.1.8 Indicate Document to Poll

Class 2.1 +FLP

Write syntax: +FLP=<value>

Valid values: 0, 1

Default value: 0

T.32 reference: 8.5.1.7

+FLP=0 The host has no document to poll.

+FLP=1 The host has a document ready for polling. The modem reports this to the remote station in the DIS frame. The modem resets this parameter to 0 after a polled document is sent.

Class 2 +FLPL

Write syntax: +FLPL=<value>

Valid values: 0, 1

Default value: 0

Class 2 reference: 2.5.1.7

The Class 2 parameter is the same as the Class 2.1 parameter except for the name.

2.5.1.9 Request to Poll

Class 2.1 +FSP

Write syntax: +FSP=<value>

Valid values: 0, 1

Default value: 0

T.32 reference: 8.5.1.8

+FSP=0 The host does not want to poll.

+FSP=1 The host can receive a polled document. The modem resets this parameter to 0 after a polled document is received.

Class 2 +FSPL

Write syntax: +FSPL=<value>

Valid values: 0, 1

Default value: 0

Class 2 reference: 2.5.1.8

The Class 2 parameter is the same as the Class 2.1 parameter except for the name.

2.5.1.10 Capability to Receive

Class 2.1 +FCR

Write syntax: +FCR=<value>

Valid values: 0, 1

Default value: 0***

T.32 reference: 8.5.1.9

+FCR=0 The modem will not receive message data; also, the modem will not be able to poll a remote device. This can be used when the host has insufficient storage, or if the modem does not have a Phase C (V.27ter, V.29) demodulator. The modem can send and can be polled for a file.

+FCR=1 The modem can receive message data.

+FCR is sampled in ITU T.30 Phase B and Phase D.

Class 2 +FCR

Write syntax: +FCR=<value>

Valid values: 0, 1

Default value: 0***

T.32 reference for Class 2: 8.5.1.9

The Class 2 parameter is identical to the Class 2.1 parameter except that it is sampled in T.30 Phases A and D***.

2.5.1.11 Session Message Reporting

Class 2.1 +FBU

Write syntax: +FBU=<value>

Valid values: 0, 1

Default value: 0

T.32 reference: 8.5.1.10

+FBU=0 Disables HDLC frame reporting.

+FBU=1 Enables the modem to report the contents of Phase B and Phase D HDLC frames to the host as they are sent and received in addition to other responses. Reports use the +FHT: and +FHR: responses described in section 2.6.

Note: See Appendix D for a description of how these commands interact: **+FBU**, **+FDB**, and **+FDD**.

Class 2 +FBUG

Write syntax: +FBUG=<value>

Valid values: 0, 1

Default value: 0

Class 2 reference: 2.5.1.10.

The Class 2 parameter is identical to the Class 2.1 parameter except for the name.

2.5.1.12 Debug Message Reporting

Class 2.1 +FDB

Write Syntax: AT+FDB=<value>

Values: 0, 1

Default: 0

T.32 reference: Non-standard Multi-Tech extension

+FDD=0 Turns off +FDB responses and +FHT/+FHR responses in page transfer mode

+FDB=1 Allows +FDB responses to come out (modified by +FDD command) and +FHR/+FHT responses to come out in page transfer modes.

Note: See Appendix D for a description of how these commands interact: **+FBU**, **+FDB**, and **+FDD**.

Class 2 +FDB

Write Syntax: AT+FDB=<value>

Values: 0, 1

Default: 0

Class 2 reference: Non-standard Multi-Tech extension

The Class 2 parameter is identical to the Class 2.1 parameter except for the name.

2.5.1.13 Debug Message Reporting Modification

Class 2.1 +FDD

Write Syntax: AT+FDD=<value>

Values: 0, 1 When set to 0

Default: 1

T.32 reference: Non-standard Multi-Tech extension

The +FDD command modifies the function of the +FDB command.

+FDD=0 Does not allow +FDB responses to come out

+FDD=1 Allows +FDB responses to come out if +FDB=1

Note: See Appendix D for a description of how these commands interact: **FBU**, **+FDB**, and **+FDD**.

Class 2 +FDD

Write Syntax: AT+FDD=<value>

Values: 0, 1 When set to 0

Default: 1

Class 2 reference: Non-standard Multi-Tech extension

The Class 2 parameter is identical to the Class 2.1 parameter except for the name.

2.5.1.14 Negotiation Reporting

Class 2.1 +FNR

Write syntax: +FNR=<rpr>,<tpr>,<idr>,<nsr>

Valid values: 0, 1 for each subparameter

Default values: 0,0,0,0

T.32 reference: 8.5.1.11

+FNR is a compound parameter, used to control the reporting of messages generated during T.30 Phase B negotiations. There are four switches, for four types of reports:

Setting	Reference	Description
rpr=0 rpr=1	2.4.2.1	Receiver parameters are not reported; +FIS: and +FTC: reports are suppressed. Receiver parameters are reported; +FIS: and +FTC: reports are generated.
tpr=0 tpr=1	2.4.2.1	Transmitter parameters are not reported; +FCS: reports are suppressed. (Note) FCS parameter is still loaded. Transmitter parameters are reported; +FCS: reports are generated.
idr=0 idr=1	2.4.2.3	ID strings are not reported; +FTI:, +FCI: and +FPI: reports are suppressed. ID strings are reported; +FTI:, +FCI: and +FPI: reports are generated.
nsr=0 nsr=1	2.4.2.4	Non-standard frames not reported; +FNF; +FNS: and +FNC: reports suppressed. Non-standard frames reported; +FNF: +FNS: and +FNC: reports generated.
<p>Note: If tpr=0, the negotiated image data format will not be reported. Without that report, the host must send image data that is mandated by Recommendation T.30 (normal resolution, A4 length, 1728 width, 1-D coding) or it must enable the corresponding format conversion (+FFC). Otherwise, the data format negotiated and the data format sent might not match, causing the facsimile session to fail.</p>		

Class 2 There is no equivalent parameter in Class 2.

2.5.1.15 Address & Polling Capabilities

Class 2.1 +FAP

Write syntax: +FAP=<sub>,<sep>,<pwd>

Valid values: 0 (disabled) or 1 (enabled) for each subparameter

Default values: 0,0,0

T.32 reference: 8.5.1.12

The +FAP subparameters allow the host to indicate the inbound subaddressing, selective polling, and passwords capabilities to the remote station via the corresponding bits in the DIS or DTC frames: bit 47 for SEP, bit 49 for SUB, bit 50 for PWD.

These subparameters also control the reporting of those frames, if received. For example, if the <sep> subparameter value is set to 0 (disabled), then the modem ignores a received SEP frame; if the <sep> subparameter is set to 1 (enabled), the modem reports the received frame using the +FPA: report.

Class 2 There is no equivalent parameter in Class 2.

2.5.1.16 Addressing & Polling Frames

Class 2.1 +FSA, +FPA, +FPW

Write syntax: +FSA="<destination Subaddress string>"

+FPA="<selective Polling Address string>"

+FPW="<Password string>"

Valid values: 20 digit numeric ASCII string: digits 0-9, *, # and space only

Default value: null string

T.32 reference: 8.5.1.13

The modem sends the numeric string contained in +FSA, +FPA or +FPW at the times specified in Recommendation T.30, if the corresponding parameter is not a null string.

The +FPW parameter is used for the PWD frame sent with either DTC or with DCS.

The +FSA=?, +FPA=?, and +FPW=? test commands report the corresponding ranges of character values supported.

The modem transmits digit string characters to the remote station in reversed time order from the order in the command line. If less than 20 characters are specified in a non-null string, the modem appends space characters. If the specified string is more than 20 characters in length, an ERROR result code is generated.

Class 2 There are no equivalent parameters in Class 2.

2.5.2 T.30 Procedure Control Parameters

The fax modem makes decisions at several nodes in the T.30 procedure. These parameters allow a host to sense or determine fax modem policy for these procedure decisions.

2.5.2.1 Page Transfer Status

Class 2.1 +FPS

Write syntax: . FPS=<ppr>

Valid values: 1, 2, 3

Default value: 1

T.32 reference: 8.5.2.2

The +FPS parameter contains a value representing the post page response, including copy quality and related end-of-page status. These values correspond to post page response messages defined in T.30. The receiving modem sets this parameter after it receives a page of Phase C data. The transmitting modem sets this parameter with the status reported by the receiving station. The host may inspect or modify this parameter. The set of <ppr> values is defined in Table 2.2.0. These values are also reported by the +FPS:<ppr> response to the +FDR command. The Multi-Tech implementation does not support <ppr> values 4 and 5.

Table 2.2.0 Class 2.1 T.30 Post Page Response Message Codes

Value	Mnemonic	Description
1	MCF	Page good.
2	RTN	Page bad; retrain requested.
3	RTP	Page good; retrain requested.
4*	PIN	Page bad; retrain requested; interrupt request accepted.
5*	PIP	Page good; interrupt request accepted.
*Supported in legacy modems only (MT28xx models and earlier, which includes MT24xx, MT19xx, MT14xx).		

The modem may set this parameter to values 1, 2 or 3 based on its own copy quality checking or access to received signal quality. The modem sets this parameter to a value of 1 if copy quality checking is disabled (+FCQ=0) S.

A receiving host may do its own copy quality checking or decide to request a procedure interrupt from the remote station. The host will receive a report of the copy quality <ppr> as part of the +FPS:<ppr>,<lc>,<bic>,<cbic> response. The host may modify this result before it issues the next action command (e.g., +FDR), which releases the corresponding post page response to the remote facsimile station.

Class 2 +FPTS

Write syntax: +FPTS=<ppr>

Valid values: 1, 2, 3, 4, 5

Default value: 1

Class 2 reference: 2.5.2.1

Except for the name and the range of values, the Class 2 parameter is identical to the Class 2.1 parameter.

2.5.2.2 Copy Quality Checking

Class 2.1 +FCQ

Write syntax: +FCQ=<rq>,<tq>

Valid values: 0, 1 for <rq>
0 for <tq>

Default values: 1 for <rq>
0 for <tq>

T.32 reference: 8.5.2.3

Other values for <rq> and <tq> are not supported in the Multi-Tech implementation.

The +FCQ parameter controls copy quality checking and correction by a facsimile modem. The <rq> subparameter controls copy quality checking and correction of data received from the remote station and delivered to the local host; the <tq> subparameter controls copy quality checking and correction of image data received from the local host and sent to the remote station.

The modem reports on Received Copy Quality to the host in the page status report, +FPS:<ppr>,<lc>,<blc>,<cblc>,<lbc>, and records it in the +FPS parameter.

+FCQ=0,0 Modem receive copy quality checking is disabled; the modem will generate copy quality OK (MCF) responses to complete pages, and set FPS=1. Modem transmit copy quality checking is disabled; the host is responsible for T.4 or T.6 compliance.

+FCQ=1,0 Modem receive copy quality checking is enabled; the modem will determine the recommended Post Page Message, and store it into the FPS parameter. Modem transmit copy quality checking is disabled; the host is responsible for T.4 or T.6 compliance.

Class 2 +FCQ

Write syntax: +FCQ=<value>

Valid values: 0, 1

Default value: 0

Class 2 reference: 2.5.2.2

This parameter controls copy quality checking by the receiving facsimile modem.

The modem will generate a page transfer report, indicated with the +FPTS=<ppr>,<lc>,<blc>,<cblc> response and posted in the +FPTS parameter. The +FCQ parameter setting also conditions the generation of bad line count <blc> and consecutive bad line count <cblc> subparameters.

+FCQ=0 The modem does no copy quality checking. The modem will generate copy quality OK (MCF) responses to complete pages, and set +FPS=1.

+FCQ=1 The modem can check 1-D Phase C data. The host must check copy quality for 2-D Phase C data. On new V.92 modems, +FCQ=1 means it will also check 2-D Phase C data.

2.5.2.3 Receive Quality Thresholds

Class 2.1 +FRQ

Write syntax: +FRQ=<pgl>,<cbl>

Valid values: 0 to 64h for <pgl>
0 to FFh for <cbl>

Default value: 0,0

T.32 reference: 8.5.2.4

This compound parameter replaces the +BADMUL and +FBADLIN parameters used in Class 2. The modem may use it to make the "Copy Quality OK" decision in the T.30 flow chart (Figure A.7/T.30). If it is used, the modem shall judge copy quality unacceptable if either the percentage of good lines is too low or too many consecutive lines contain errors. Bad line counts are reported in the +FPS:<blc> response. A value of 0 disables either subparameter for use in copy quality checking.

The first subparameter, <pgl>, specifies the percentage of good lines (e.g. with negotiated number of pixels) required for a page to be considered acceptable. For example, if the modem counted bad lines (as reported in the +FPS <blc> subparameter) and total line count (as reported in the +FPS<lc> subparameter); the percentage of good lines would be computed by the following equation:

$$100 \times (\text{lc} - \text{blc}) / \text{lc}$$

If the resulting value is less than the value in <pgl>, the page is unacceptable.

The second subparameter, <cbl>, specifies the maximum tolerable number of consecutive bad lines. If this value is exceeded for a given page, the modem shall consider the page unacceptable.

If the page is found unacceptable by either criteria, the modem shall report the value 2 (see Table 17) for the +FPS <ppr> subparameter, and store that value into the +FPS parameter.

Class 2 +FBADMUL

Write syntax: +FBADMUL=<value>

Valid values: 0–255

Default value: 20

Class 2 reference: 2.5.2.3

This is one of two Class 2 parameters used to determine "Copy Quality OK" on the T.30 flow chart. The number of lines received with a bad pixel count is multiplied by this number. If the result exceeds the number of lines in the page, then the error rate is too high. A value of 20 corresponds to a 5% error rate.

A value of 0 implies that error checking is not present or is disabled.

Class 2 +FBADLIN

Write syntax: +FBADLIN=<value>

Valid values: 0–255

Default value: 10

Class 2 reference: 2.5.2.4

This is the other Class 2 parameter used to determine “Copy Quality OK.” If the number of consecutive lines in normal resolution (98 dpi) mode that have pixel count errors is equal to or greater than <value>, then the copy quality is unacceptable. If the number of consecutive lines in fine resolution (196 dpi) mode that have pixel count errors is equal to or greater than <value> × 2, then the copy quality is unacceptable. “Copy Quality Not OK” occurs if either the error percentage is too high or if too many consecutive lines contain errors. Bad line counts are reported in the +FPTS: response.

A value of 0 implies that error checking is not present or disabled.

2.5.2.4 Adaptive Answer**Class 2.1 +FAA**

Write syntax: +FAA=<value>

Valid values: 0, 1

Default value: 0

T.32 reference: 8.5.2.5

+FAA=0 The modem shall answer only as a Class 2.1 facsimile device. No automatic switching of service class shall occur based on the calling device type.

+FAA=1 The modem can answer and automatically determine whether to answer as a facsimile modem or as a data modem. If the modem automatically switches, it resets the +FCLASS parameter to 0. +FCLASS does not affect switching to Class 2.1 from other classes or switching to classes other than Class 0.

Note: If the modem reconfigures itself to data modem operation in adaptive answering, the host must reissue a new +FCLASS=2.1 command to enable subsequent Service Class 2.1 facsimile operation.

Class 2 +FAA

Write syntax: +FAA=<value>

Valid values: 0, 1

Default value: 0

Class 2 reference: 2.5.4.1

+FAA=0 Constrains the modem to answer as set by +FCLASS.

+FAA=1 The modem can answer and automatically determine whether to answer as a facsimile modem or as a data modem. If the modem automatically switches, it modifies FCLASS as appropriate.

2.5.2.5 Host Phase C Response Timeout, +FCT

Write syntax: +FCT=<value>

Valid values: 0–255 in 100 millisecond units.

Default value: 30

This determines how long the modem waits for a command after reaching the end of data when transmitting in Phase C. When this time-out is reached a cancellation signal and then a +FHS:43 is issued to the host and the remote side is sent a disconnect frame.

2.5.2.6 +FPHCTO, Host Phase C Response Time-out

Class 2.1/2.0 Not applicable.

Class 2

Syntax: +FPHCTO=<value>

Value Values: 0 – 255

Default Value: 30

+FPHCTO=? 0-255 +FPHCTO? 30 Default value. Range:0 - 255

This command specifies the waiting period during a fax transmission beyond which the transmission is automatically terminated with an end-of-page command.

2.5.2.7 T.30 Session Error Report, +FAXERR

Class 2.0/2.1 Not supported

Class 2 +FAXERR

Read syntax: >+FAXERR=<table value>, read only

Valid values: 0–255; see Table 2.3 for meaning

This read only parameter indicates the cause of a hangup. Table 2.3 shows the valid values for this parameter as well as the meaning of each value. +FAXERR is set by the modem at the conclusion of a fax session. The modem will reset this to 0 at the beginning of Phase A off-hook time.

2.5.2.8 Minimum Phase C Speed, +FMS

Class 2.0/2.1 +FMS

Write syntax: +FMS=BR

Valid values: 0–5, in BR subparameter codes

Default value: 0 (V.27ter @ 2400 bit/s)

This optional parameter limits the lowest negotiable speed for a session. It is useful for limiting the cost of a transmission by requiring a minimum transmission speed. If a facsimile cannot negotiate to a minimum speed, it performs an orderly disconnect.

The units are the same as those defined for the BR Bit Rate subparameter as defined in Table 2.4 in this manual.

Class 2 +FMINS

Write syntax: +FMINS=BR

Valid values: 0–5, in BR subparameter codes

Default value: 0 (V.27ter @ 2400 bit/s)

This optional parameter limits the lowest negotiable speed for a session. It is useful for limiting the cost of a transmission by requiring a minimum transmission speed. If a facsimile cannot negotiate to a minimum speed, it performs an orderly disconnect. The

units are the same as those defined for the BR Bit Rate subparameter, as defined in Table 2.4 in this manual.

2.5.3 Phase C Data Format Parameters

2.5.3.1 Data Bit Order: +FBO and +FBOR

Class 2.0/2.1 +FBO

Write syntax: +FBO=<value>

Valid values: 0, 1

Default value: 0

This parameter controls the mapping between PSTN facsimile data and the host-modem link. There are two choices:

+FBO=0 Direct bit order for both Phase C data. The first bit transferred of each byte on the host-modem link is the first bit transferred on the PSTN data carrier.

+FBO=1 Reversed bit order for Phase C data. The last bit transferred of each byte on the host-modem link is the first bit transferred on the PSTN data carrier.

The effect of this parameter is illustrated for the EOL pattern in section 2.5.3.3.

Class 2 +FBOR

Write syntax: +FBOR=<value>

Valid values: 0, 1

Default value: 0

This parameter controls the mapping between PSTN facsimile data and the host-modem link. There are two choices:

+FBOR=0 Direct bit order for both Phase C data. The first bit transferred of each byte on the host-modem link is the first bit transferred on the PSTN data carrier.
Applies to FAX sending for all Multi-Tech modems; applies to FAX receiving for all Multi-Tech legacy modems.

+FBOR=1 Reversed bit order for Phase C data. The last bit transferred of each byte on the host-modem link is the first bit transferred on the PSTN data carrier.
Applies to FAX sending for all Multi-Tech modems; applies to FAX receiving for all Multi-Tech legacy modems.

The effect of this parameter is illustrated for the EOL pattern in section 2.5.3.3.

2.5.3.2 Receive Data Bit Order, +FRBOR (legacy modems only)

Write Syntax: +FRBOR = <value>

Valid Values: 0, 1

Default: 0

This parameter controls the bit order of phase C received fax data. It was intended as a compatibility option to make the received bit order like that of Rockwell/Conexant-based Class 2 modems.

+FRBOR = 0 Specifies that +FBOR=0 is direct bit order and that +FBOR=1 is reversed bit order.

+FRBOR = 1 Specifies that +FBOR=1 is direct bit order and that +FBOR=0 is reversed bit order. This setting emulates the behavior of Rockwell/Conexant-based Class-2 modems.

* Legacy modems are models MT28xx models and earlier, which includes MT24xx, MT19xx, MT14xx.

Table of Bit-Order Commands

Modem /Chipset	Class	+FBO = 0 / +FBOR = 0			+FBO = 1 / +FBOR = 1		
			+FRBOR=0	+FRBOR=1		+FRBOR=0	+FRBOR=1
		Send	Receive	Receive	Send	Receive	Receive
MTS Legacy	2	D	D	R	R	R	D
Agere (Lucent)	2	D	R	n/a	R	D	n/a
Agere (Lucent)	2.0/2.1	D	D	n/a	R	R	n/a
where: D denotes direct bit order R denotes reversed bit order							

2.5.3.3 Phase C Received EOL Alignment: +FEA and +FREL**Class 2.0/2.1 +FEA**

Write syntax: +FEA=<value>

Valid values: 0, 1

Default value: 0

+FEA=0 EOL patterns are bit-aligned as received.

+FEA=1 The last received bits of EOL patterns are byte-aligned by the modem, with necessary zero fill bits inserted. There are two 2-byte binary EOL patterns, in which xxxx represents previous data bits, zero bits, or other leading data:

+FBO=0: 0000xxxx 10000000

+FBO=1: xxxx0000 00000001

Class 2 +FREL

Write syntax: +FREL=<value>

Valid values: 0, 1

Default value: 0

+FREL=0 EOL patterns are bit-aligned as received.

+FREL=1 The last received bits of EOL patterns are byte-aligned by the modem, with necessary zero fill bits inserted. There are two 2-byte binary EOL patterns, in which xxxx represents previous data bits, zero bits, or other leading data:

+FBOR=0: 0000xxxx 10000000	for legacy modems
+FBOR=1: xxxx0000 00000001	
+FBOR=1: 0000xxxx 10000000	for all modems other than legacy
+FBOR=1: xxxx0000 00000001	

2.5.3.4 Format Conversion, +FFC

Class 2.0/2.1

Write syntax: +FFC=<vrc>,<dfc>,<inc>,<wdc>

Valid values: See table below

Default values: manufacturer's option

Mandatory values: 0,0,0,0

This compound parameter determines the modem response to mismatches between the Phase C data delivered after the +FDT command and the data format parameters negotiated for the facsimile session. [See +FCS: response (8.4.2.1) and +FCS parameter (8.5.1.3) in T.32 standard.]

For mismatch checking, the modem depends on the host to indicate the data format with embedded <DLE><format> character pairs. If these format indicators are not provided, the modem shall assume that the format is as negotiated for that session.

For each subparameter, value 0 determines that mismatch checking is disabled, and all format codes of this type are ignored. Value 1 determines that mismatch checking is enabled, with session termination if the format codes do not match the negotiated format reported in +FCS: responses. Other values enable degrees of format conversion.

Unspecified values are reserved.

Setting	Description
vrc=0 vrc=1 vrc=2 vrc=3	Vertical resolution format codes ignored Vertical resolution checking enabled Vertical resolution conversion enabled for 1-D data Vertical resolution conversion enabled for 2-D data
dfc=0 dfc=1 dfc=2	Data format format codes ignored Data format checking enabled Data format conversion enabled
inc=0 inc=1 inc=2 inc=3	Page length format codes ignored Page length checking enabled Page length conversion enabled for 1-D data Page length conversion enabled for 2-D data
wdc=0 wdc=1 wdc=2	Page width format codes ignored Page width checking enabled Page width conversion enabled

Class 2 Not applicable

Note that the four arguments of the Class 2.0/2.1 command +FFC cover the same technical content as these four separate Class 2 commands (which are described in detail below):

- +FVRFC (for vertical resolution),
- +FDFFC (for data compression format version),
- +FLNFC (for page length format conversion), and
- +FWDFC (for page width format conversion).

2.5.3.5 Vertical Resolution Format Conversion, +FVRFC

Class 2.0/2.1 Not applicable

Class 2

Write syntax: +FVRFC=<value>

Valid values: 0, 1, 2

Default value: 0

This parameter determines the modem response to a mismatch between the vertical resolution negotiated for the facsimile session, reported by the +FCS:VR subparameter, and the Phase C data desired by the host, indicated by the optional +FDT:VR subparameter, or the +FIS=VR subparameter for +FDR operation.

FVRFC=0 Disables mismatch checking. The host must check the +FCS:VR subparameter, and transfer matching data.

FVRFC=1 Enables mismatch checking. An implied +FKS command is executed on mismatch detection.

FVRFC=2 Enables mismatch checking, with resolution conversion of 1-D data in the modem. An implied +FKS command is executed on 2-D mismatch detection.

2.5.3.6 Data Compression Format Conversion, +FDFFC

Class 2.0/2.1 not applicable

Class 2

Write syntax: +FDFFC=<value>

Valid values: 0

Default value: 0

This parameter determines the modem response to a mismatch between the data format negotiated for the facsimile session, reported by the +FCS:DF subparameter, and the Phase C data desired by the host, indicated by the optional +FDT:DF subparameter, or the +FIS=DF subparameter for +FDR operation.

FDFFC=0 Disables mismatch checking. The host must check the +FCS:DF subparameter, and transfer matching data.

2.5.3.7 Page Length Format Conversion, +FLNFC

Class 2.0/2.1 Not applicable

Class 2

Write syntax: +FLNFC=<value>

Valid values: 0, 1, 2

Default value: 0

This parameter determines the modem response to a mismatch between the page length negotiated for the facsimile session, reported by the +FCS:LN subparameter, and the Phase C data desired by the host, indicated by the optional +FDT:LN subparameter, or the +FIS=LN subparameter for +FDR operation. A mismatch would require clipping or scaling a longer format to a shorter one.

FLNFC=0 Disables mismatch checking. The host must check the +FCS:LN subparameter and transfer matching data.

FLNFC=1 Enables mismatch checking. An implied +FKS command is executed on mismatch detection.

FLNFC=2 Enables mismatch checking, with page length conversion of 1-D data in the modem. An implied +FKS command is executed on 2-D mismatch detection.

2.5.3.8 Page Width Format Conversion, +FWDFC

Class 2.0/2.1 Not applicable

Class 2

Write syntax: +FWDFC=<value>

Valid values: 0, 1, 2

Default value: 0

This parameter determines the modem's response to a mismatch between the page width negotiated for the facsimile session, reported by the +FCS:WD subparameter, and the Phase C data desired by the host, indicated by the optional +FDT:WD subparameter, or the +FIS=WD subparameter for +FDR operation. A mismatch would require clipping or scaling a wider format to a narrower one.

FWDFC=0 Disables mismatch checking. The host must check the +FCS:WD subparameter and transfer matching data.

FWDFC=1 Enables mismatch checking. An implied +FKS command is executed on mismatch detection.

FWDFC=2 Enables mismatch checking with page width conversion in the modem.

2.5.3.9 Fax Flow Control, +FLO

Syntax: +FLO=<value>

Valid values: 0, 1, 2

Default value: 1

The +FLO command allows the host to select and identify the types of flow control provided and used. A TR29-standard modem can support XON/XOFF flow control. XON is the ASCII <DC1> character (11h); XOFF is the ASCII <DC3> character (13h). The modem may provide ITU-T V.24 circuits 106 (CTS) and 133 (RTS) for flow control.

+FLO=0 No fax flow control.

+FLO=1 Software fax flow control (XON/XOFF flow control in either direction).

+FLO=2 Hardware fax flow control. ITU-T circuit 133 (RTS) is used for flow control of the modem by the host. Circuit 106 (CTS) is used for flow control of the host by the modem.

If circuits 106 and 133 are not being used for flow control (+FLO=2), then circuit 106 drops when an XOFF is sent, and goes high when an XON is sent. The conductor used for circuit 133 normally reverts to use as circuit 105 (RTS) when not being used for flow control.

2.5.3.10 Prefix Output On Query Response, +FV (supported in legacy modems only)

Syntax: +FV=<value>

Valid values: 0, 1

Default value: 1

This command controls whether the query prefix (e.g., +FCLASS=) should be output if a fax parameter is queried (e.g., +FCLASS?). If +FV=1, then fax parameter values are preceded by the query prefix when doing a fax parameter query. Example: If +FV=1, then AT+FCLASS? returns **+FCLASS=0**. If +FV=0, then AT+FCLASS? returns **0**.

+FV=0 No prefix is output on query response.

+FV=1 A prefix is output on query response.

2.5.3.11 Set Current Time and Date, AT+FTD

The AT+FTD command is used to set the current date and time. The current time and date will be tracked automatically by the modem once the time and date are set.

However, these boards do not have a real time clock. So, the accuracy of the time and date is not guaranteed. It is recommended that the current time and date is set before each FAX transmit session.

Syntax: AT+FTD=<year>, <month>, <hour>, <minute>, <second>, <zone>, <dtsdelta>

The arguments to this command are:

<year> The current year (UTC zone). Range: 1970 to 65535

<month> The current month number (UTC zone). Range: 1 to 12. January is 1.

<day> The current day of the month. Range: 1 to 31.

<hour> The current hour in military time (UTC zone). Range: 0 to 23.

<minute> The current minute (UTC zone). Range 0 to 59.

<second> The current second (UTC zone). Range 0 to 59.

<zone> The number of seconds east (positive) or west (negative) that the local time zone is from Greenwich. Range: -43200 to 43200.

<dtsdelta> Zero if daylight savings time is not in effect at the current time.

Otherwise, the number of minutes to add to the time. Range 0 to 255.

The current local time is calculated from the UTX (Universal Coordinated Time, i.e., GMT) time specified in this command, plus the <zone> offset, plus the <dtsdelta> offset, plus the number of seconds accumulated by the board since the command was executed.

2.5.3.12 Page Header Generation, AT+FPH

The AT+FPH command is used to enable automatic generation of a FAX page header.

These are the legal formats for the syntax of this command:

AT+FPH=*mode*, "*left*"(*string* is left justified)
 AT+FPH=*mode*, "*left'middle' right*"
 AT+FPH=*mode*, "*left 'right*"

The arguments to this command are:

mode: The *mode* argument controls generation of the page header.

A *mode* of 0 disables page header generation. A *mode* of 1 enables page header generation and the page header is appended to the FAX page data. A *mode* of 2 enables page header generation and the page header is overlaid on the first few lines of the FAX page data.

string: The string defines the page header itself. Only ASCII printable characters are allowed in the string (0x20 thru 0x7e). Escape sequences that are introduced with the percent (%) character are allowed. The string can be partitioned into one, two, or three parts by using single-quote characters (') in the command expression.

An escape sequence is a "%" followed by an optional width, which may include a leading left-justification signifier, and then by the escape character itself. It is of the form:

%[*numbers*][*-*]character.

The dash ("-") denotes left justification. When the dash is absent, right justification is used. If the width specification starts with a zero, then, when the escape sequence is expanded, the value will be left-padded with zeroes. Otherwise, it will be left-padded with spaces.

The following escapes are recognized:

%d(or %D) The day of the month as a decimal number (range 01 to 31).
 %h (or %H) The hour as a decimal number using a 24-hour clock (range 00 to 23).
 %i (or %I) The hour as a decimal number using a 12-hour clock (range 01 to 12).
 %j (or %J) The day of the year as a decimal number (range 001 to 366).
 %m The month as a decimal number (range 01 to 12).
 %M The minute as a decimal number (two digits).
 %p Either 'am' or 'pm' according to the given time value, or the corresponding strings.
 %P The current page number of the FAX being sent, as computed by the padding.
 %r (or %R) The ID of the remote FAX machine.
 Leading and trailing blanks are stripped. A print-style field width specifier such as %20r or %-20r can be used to print this always in a fixed width field.
 %s (or %S) The second as a decimal number (two digits).
 %t (or %T) The ID of the transmitting FAX machine. Leading and trailing blanks are stripped. A print-style field width specifier such as %20t or %-20t can be used to print this always in a fixed width field.
 %y The year as a decimal number without a century.
 %Y The year as a decimal number including the century.
 %% A literal '%' character.

If the string contains single quotes, it will be partitioned into left, and also possibly, middle and right parts.

left This portion of the header will be left justified.

middle This portion of the header will be centered.

right This portion of the header will be right justified.

Percent-introduced escapes are processed as above.

2.5.4 Miscellaneous Parameters

2.5.4.1 Buffer Size, +FBS

(Class 2.1 only)

Read syntax: +FBS?

Modem response syntax: <bs>,<xoft>,<xont>,<bc>, where

<bs> = total buffer size,

<xoft> = XOFF threshold,

<xont> = XON threshold,

<bc> = current buffer byte count

This parameter allows the host to determine the characteristics of the modem's data buffer. Flow control is mandatory; buffers are needed for flow control. Use of the reported values would allow a host to transfer data without provoking XOFF.

2.6 Session Message Report Responses

The modem may be commanded to report the T.30 Phase B and Phase D HDLC control frames as they are sent and received. This service supports session diagnostics and the debugging of host software. It is enabled by the +FBU parameter described in section 2.5.1.10.

These messages are not generated in direct execution of host action commands; they are generated for each frame whenever the reported frame is sent or received. The host should not attempt to change serial port speed or parity with +FBU set. It is desirable to suppress echo of host commands, if the modem provides that facility.

The data will be reported with each T.30 command separated by <CR><LF>. The fill bits will be removed. The frame octets will be represented in hex notation, and separated by spaces. Flags and zero bits are removed. Frame octets are reported in the order sent or received. FCS bytes are deleted. Frame octets are presented with the LSB as the first bit sent or received.

The following is an example of a received DIS string report:

+FHR: FF 13 80 00 4E 78 FE AD<CR><LF>

Unless specified otherwise, the modem reports these frames before the corresponding responses are generated. For example, the above examples would occur before the standard +FIS: report was made.

2.6.1 Report Transmit HDLC Frames, +FHT:

Syntax: +FHT:<transmitted HDLC frame octets>

Reports the HDLC data that was sent by the modem.

2.6.2 Report Received HDLC Frames, +FHR:

Syntax: +FHR:<received HDLC frame octets>

Reports the HDLC data that was received by the modem.

2.7 Debug Message Report Responses

When the modem has debug messaging enabled (with +FDB=1), then +FDB responses may be displayed.

2.7.1 Report Debug Messages, +FDB:

Syntax: +FDB:"<debug information>"

Reports some debug information supplied by the modem.

2.7.2 Debug Message Display in Page Transfer Modes

There is no standard method of displaying debug or frame information while sending or receiving a fax page. Below we indicate how it is done.

+FHT/+FHR/+FDB Responses in Send Mode:

When sending a fax in class 2.x mode, there is no standard for displaying control frames (HDLC) after the CONNECT has been put out. The only thing that the DCE should send back to the DTE when the DTE is sending page data to the DCE is a CAN (0x18) character.

When +FDB=1 is set, then in addition to the possibility of CAN chars coming back, +FHT and +FHR responses are also sent. The DTE needs to be aware of this so it can handle these.

```
CONNECT
+FDB: " (1AAB): [0-2] "
+FDB: " (1AAE): [1-0] "
```

+FHT/+FHR/+FDB Responses in Receive Mode:

When receiving a fax in class 2.x mode with +FDB=1, the modem puts out a DLE escape sequence before the response (DLE SOH – 0x10 0x01) and a different escape sequence before transitioning back to page data (DLE EOT – 0x10 0x04). The DTE will need to modify its receiving software so that it detects these and sends the response data off to a log between these two sequences and resumes storing the page data outside of these response sequences. All the data within the double quotes can be ignored by the fax software. It does have a regular format however. After the opening double quote is a 4 digit hexadecimal value (that wraps from FFFF to 0000) surrounded by parentheses. This indicates a millisecond time stamp of when the debug came out. Following that is a colon and an optional exclamation point. If the exclamation point comes out, then some debug data was lost because there was no room to put it into the modem's receive buffer.

```
CONNECT
--page data--
DLE-SOH
+FDB: " (1AAB) : [1-0] "
DLE-EOT
--more page data--
DLE-SOH
+FHR: FF 13 BF 00 00 00 FF
DLE-EOT
--more page data--
DLE-SOH
+FDB: " (4530) : ! [4-0] "
DLE-EOT
--even more page data (above some debug information
was lost -- see ! in response)
DLE-ETX
```

Chapter 3 – Fax S-Registers

3.1 Command +FS

Write Syntax: AT+FS*n*=*m*

Where *n* is the number of Fax S-Register and *m* is the value to which the S-Register is being set.

Values: Valid values depend on the S-Register. See the table below.

Default: See the table below.

Note: Depending on the level of firmware in the modem and the modem model number, these commands may not be available (even when updated to the latest firmware). Check your modem by entering the following command:

AT+FS*n*=? Where *n* is the number of the Fax S-Register.

If these commands are not implemented, the modem will issue:

ERROR

or

00 and OK (indicates that the range of acceptable values is only zero)

Register #	Valid Values	Default	Units	Description
0	0-255	20	10 ms	how long to initially ignore V.21 detector at the beginning of the page detection period while waiting for non-V.34 page data
1	0-255	20	1 ms	how often to check the V.21 detector bit after the ignore period is over
2	0-255	3		how many positive detections are necessary to determine that it is a V.21 frame instead of a high speed frame
3	0-255	0	10 ms	how long to wait for silence after receiving a page if carrier was lost.
4	0-255	0	1 ms	number of extra milliseconds between DCS and TCF frames when sending a fax
5	0-255	0	10 ms	how much longer to extend the TCF when sending a fax
6	0-5	5		maximum non-ECM baud rate (same values as BR in +FCS, etc).
12	0-255	100	percent	The percentage of a length of all zero bytes that is normally expected to be received for a given speed for a TCF to be good. For example, for the speed 14,400 baud, the modem normally expects a run of 1,800 zeros to declare the TCF good. If this register was set to 80, then the modem would look for a run of (1,800 x 0.80 = 1440) zeros to decide that the TCF is good.
13	0-255	243	n/a	This is a bit mapped register where each bit indicates whether an echo protect tone is on for each speed when sending a fax 128 - 14.4K V.17 64 - 12K V.17 32 - 9.6K V.17 16 - 7.2K V.17 8 - 9.6K V.29 4 - 7.2K V.29 2 - 4.8K 1 - 2.4K
14	0-15	1	dB	Sets the transmit compromise equalization for the phone line. This value (in dB) specifies the slope in the transmit spectrum in dB between 1000 Hz and 2800 Hz. This normally does not need to be modified.

Appendix A – Sample Modem Control Sessions

A1. Send two pages, 1-D data, no errors (Class 2)

Host Commands	Modem Responses	Local Modem Action	Remote Station Action	Notes
AT+FCLASS=2	OK	Set Class 2		
AT+FLID="<local ID>"	OK	Set local ID		
ATD<dial string>	+FCON [+FCSI:"<csi.>"] +FDIS:<dis codes. OK	off hook, dial, send CNG detect flags [get CSI] get DIS	answer, send ([CED], V.21 flags, [CSI], DIS	
AT+FDT	+FDCS:<dcs codes> CONNECT <XON>	[send TSI] send DCS send TCF get CFR send carrier	[get TSI] get DCS get TCF send CFR receive carrier	
<1st page data>		send page data	receive page data	
<DLE><ETX>	OK			
AT+FET=0	+FPTS:1 OK	send RTC send MPS get MCF	get RTC get MPS send MCF	
AT+FDT	CONNECT <XON>	send carrier	receive carrier	
<2nd page data>		send page data	receive page data	
AT+FET=2	+FPTS:1 +FHNG:0 OK	send RTC send EOP get MCF send DCN hangup	get RTC get EOP send MCF get DCN hangup	

A2. Receive two pages, 1-D data, no errors (Class 2)

Host Commands	Modem Responses	Local Modem Action	Remote Station Action	Notes
AT+FCR=1	OK	Enable Reception		
AT+FLID="<local ID>"	OK	Set local ID		
	RING <-	Detect ring <-	Dials[, send CNG]	
ATA	+FCON [+FCSI"<tsi>"] +FDIS:<dis codes. OK	off hook, send CED, send CSI, send DIS, detect flags, [get TSI] get DIS begin TCF recv	get CED, get CSI, get DIS, send V.21 flags, [send TSI], send DIS, start TCF	
AT+FDR	+FCFR +FDCS:<dcs codes> CONNECT	accept TCF send CFR get page carrier	finish FCT get CFR send page carrier	
<DC2>	<page data stream> <DLE><ETX><- +FPTS:1,<lc> +FET:0 <- OK	get page data detect RTC <- get MPS	send page data send RTC drop carrier, send MPS	
AT+FDR	+FHNG:0 <- OK	send MCF get DCN <-	get MCF send DCN	

A3. Send two pages, 1-D data, no errors (Class 2.0)

Square bracketed [] responses are conditional on the remote station actions; curly bracketed { } responses are conditional on switches set by the host. For this example, all reports are enabled: +FNR=1,1,1,1. Square bracketed [] commas are optional for the host.

Host Commands	Modem Responses	Local Modem Action	Remote Station Action	Notes
AT+FCLASS=2.0	OK	Set Class 2		
[AT+FPW="<sending password string>"]	OK	Set local PWD		host may load a Password
[AT+FSA="<SUB string>"]	OK	Set SUB		Host may load a destination Subaddress
[AT+FLI="<local ID>"]	OK	Set local ID		host may load a local ID
ATD<dial string>	+FCO [+FNF:<nsf>] [+FCI:"<csi>"] {+FIS:<dis codes>} OK	off hook, dial, send CNG detect flags [get NSF] [get CSI] get DIS	answer, send [CED], preamble, [NSF,] [CSI,] DIS	
[AT+FNS="<hex NSS FIF string>"]	OK			host may respond to NSF frame
AT+FDT <1st page data> <RTC pattern> <DLE><mps>	{+FCS:<codes>} CONNECT OK	[send NSS,] [send PWD,] [send SUB,] [send TSI,] send DCS send TCF get CFR send carrier send page data send RTC send MPS get MCF	[get NSS,] [get PWD,] [get SUB,] [get TSI,] get DCS get TCF send CFR get carrier get data get RTC get MPS send MCF	if +FNS loaded if +FPW loaded if +FSA loaded if +FLI loaded
AT+FDT <2nd page data> <RTC pattern> <DLE><eop>	CONNECT +FHS:00 OK	send carrier send 2nd page send RTC send EOP get MCF send DCN hangup	receive carrier get 2nd page get RTC get EOP send MCF get DCN hangup	

A4. Receive two pages, 1-D data, no errors (Class 2.0)

In this example, the remote station sends NSS, SUB, PWD and TSI. The local modem has +FNR=1,1,1,1 and +FAP=1,1,1.

Host Commands	Modem Responses	Local Modem Action	Remote Station Action	Notes
AT+FCR=1	OK	Enable Reception		
[AT+FLI="<local ID>"]	OK	Set local ID		host may load the local ID
[AT+FNS="<hex NSF FIF string>"]	OK			host may set up NSF string
	RING <-	Detect ring <-	Dials[,send CNG]	
ATA	+FCO +FNS:<nss string> +FPW:<pwd string> +FSA:<sub string> +FTI:"<tsi ID>" {+FCS:<dcs codes>} OK	off hook, send CED, [send NSF,] [send CSI,] send DIS, detect flags, get NSS, get PWD, get SUB, get TSI, get DCS begin TCF recv	get CED, [get NSF,] [get CSI,] get DIS, send Preamble, send NSS, send PWD, send SUB, send TSI, send DCS, start TCF	if +FNS loaded if +FLI loaded
AT+FDR	[+FCS:<dcs codes>] CONNECT <page data> <RTC pattern> <DLE><ETX> +FPS:1,<lc>,0,0,0 +FET:0 <- OK	accept TCF send CFR get page carrier get page data detect RTC <- get MPS <-	finish TCF get CFR send carrier send page data send RTC, send MPS	Another +FCS would be reported if the parameters changed after retraining
AT+FDR <DC2>	CONNECT <page data> <RTC pattern> <DLE><ETX> <- +FPS:1,<lc>,0,0,0 +FET:2 OK	send MCF get carrier get page data detect RTC <- get EOP <-	get MCF send carrier send page data send RTC, send EOP	
AT+FDR	+FHS:00 <- OK	send MCF get DCN <- hangup	get MCF, send DCN hangup	

A5. Originate and send a two page facsimile with V.34 half-duplex (Class 2.1)

Optional T.30 frames are omitted. +FNR=1,1,, +FIS and +FCS subparameters other than BR and EC are not shown.

Host Commands	Modem Responses	Local Modem Action	Remote Station Action	Notes
ATFCLASS=2.1	OK	Set class 2		
ATFIS=B,3,,	OK	Set for Rec. V.34, Annex A/T.30, Annex C/T.30 or Annex F/T.30		
ATD<dial string>	.FCO .FIS:B,1,, OK	off-hook, dial, send CNG detect ANSam send CM get JM send CJ negotiate Rec. V.34 begin control chan get DIS	detect ringing answer detect CNG send ANSam get CM send JM get CJ negotiate Rec. V.34 begin control chan send DIS	("Chan" = channel) Rec. T.30 selected with JM signal from remote terminal the remote indicated 28 800 bit/s ability
ATFDT <1st page data> <DLE><mps>	.FCS:9,1, CONNECT OK	send DCS get CFR switch to primary chan send page FCD switch to control chan send MPS get MCF	get DCS send CFR switch to primary chan get page data switch to control chan get MPS send MCF	in this example, 24 400 bit/s is selected
AT+FDT <2nd page data> <DLE><eop>	CONNECT +FHS:00 OK	switch to primary chan send page 2 FCD switch to control chan send EOP get MCF send DCN hangup	switch to primary chan get page 2 FCD switch to control chan get EOP send MCF get DCN hangup	

A6. Answer and receive a two-page facsimile with V.34 half-duplex (Class 2.1)

Host Commands	Modem Responses	Local Modem Action	Remote Station Action	Notes
AT+FCLASS=2.1	OK	Set class 2		
AT+FIS=D,,,,3 ,,,,	OK	Set for Rec. V.34, Annex A/T.30, Annex C/T.30 or Annex F/T.30		select max rate of 33 600 bit/s
	RING	detect ringing	off-hook, dial	
ATA	+FCO OK	answer detect CNG send ANSam get CM send JM get CJ negotiate Rec. V.34 begin control channel send DIS	send CNG detect ANSam send CM get JM send CJ negotiate Rec. V.34 begin control channel get DIS	Rec. T.30 selected with JM signal from remote terminal the remote indicated 28 800 bit/s ability
AT+FDT	+FCS:B,,,,1,,,, CONNECT <1st page data> <DLE><ETX> +FPS:1,<lc>,0,0,0 +FET:0 OK	get DCS send CFR switch to primary channel get page 1 FCD switch to control channel get MPS	send DCS get CFR switch to primary channel send page 1 FCD switch to control channel send MPS	in this example, 28 800 bit/s is selected
AT+FDR	CONNECT <2nd page data> <DLE><ETX> +FPS:1,<lc>,0,0,0 +FET:2	send MCF switch to primary channel get page 2 FCD switch to control channel get EOP	get MCF switch to primary channel send page 2 FCD switch to control channel send EOP	
AT+FDR	+FHS:00 OK	send MCF get DCN hangup	get MCF send DCN hangup	

Appendix B – Alphabetic List of Commands and Responses

Name	Description
A	Answer command
D<string>	Originate command
+FAA=	Auto Answer Mode parameter
+FAXERR=	Fax Error Value parameter
+FBADLIN=	Number of Consecutive Bad Lines for a Bad Page parameter
+FBADMUL=	Error Threshold Multiplier
+FBO=	Phase C Data Bit Order parameter
+FBS?	Buffer Size, read-only parameter
+FBU=	Session Message Reporting parameter
+FPI:	Report Remote ID response, CIG
+FCFR	Confirmation to Receive prompt
+FCLASS=	Service Class ID
+FCO	Facsimile Connection response
+FCQ=	Copy Quality Capabilities parameter
+FCR=	Capability to Receive parameter
+FCI:	Report remote ID response, CSI
+FPI=	Local Polling ID String parameter
+FCS:	Report Session Parameters response
+FCS=	Current Session results
+FDFFC=	Data Compression Format Conversion parameter
+FCC=	modem Capabilities parameters
+FIS:	Report Remote Capabilities response
+FIS=	Current Session Negotiation parameters
+FDR	Receive Phase C Data command
+FDT[=]	Transmit Phase C Data command
+FRY=	CTC Retry Value
+FTC:	Report Remote capabilities response
+FET:	Post Page Message response
+FET=	End the Page or Document command
+FHS:	Call Termination Status response
+FHR:	Report Received HDLC Frame response
+FHT:	Report Transmitted HDLC Frame response
+FKS	Orderly Fax Abort command
+FLI=	Local ID String parameter, TSI/CSI
+FLNFC=	Page Length Format Conversion parameter
+FLO	Fax Flow Control
+FLP=	Document for Polling parameter

Name	Description
+FMM?	Request modem Model
+FMI?	Request modem Manufacturer
+FMS=	Minimum Phase C Speed parameter
+FNC:	Report NSC Frame response
+FNF:	Report NSF Frame response
+FNS:	Report NSS Frame response
+FCT=	Phase C Timeout parameter
+FPO	Remote Polling Indication
+FPS:	TX Page Transfer Status response
+FPS=	Page Transfer Status parameter
+FMR?	Request modem Revision
+FEA=	Phase C EOL Alignment parameter
+FSP=	Enable Polling parameter
+FTI:	Report Remote ID response, TSI
+FVO	Transition to Voice response
+FV	Prefix Output On Query response
+FVRFC=	Vertical Resolution Format Conversion parameter
+FWDFC=	Page Width Format Conversion parameter
+FTBC	Phase C Transmit Byte Count
+FRBC	Phase C Receive Byte Count

Appendix C – ASCII Conversion Chart

CTRL CODE				HEX				DEC				
@	NUL	00	0	SP	20	32	@	40	64	`	60	96
A	SOH	01	1	!	21	33	A	41	65	a	61	97
B	STX	02	2	"	22	34	B	42	66	b	62	98
C	ETX	03	3	#	23	35	C	43	67	c	63	99
D	EOT	04	4	\$	24	36	D	44	68	d	64	100
E	ENQ	05	5	%	25	37	E	45	69	e	65	101
F	ACK	06	6	&	26	38	F	46	70	f	66	102
G	BEL	07	7	'	27	39	G	47	71	g	67	103
H	BS	08	8	(28	40	H	48	72	h	68	104
I	HT	09	9)	29	41	I	49	73	i	69	105
J	LF	0A	10	*	2A	42	J	4A	74	j	6A	106
K	VT	0B	11	+	2B	43	K	4B	75	k	6B	107
L	FF	0C	12	,	2C	44	L	4C	76	l	6C	108
M	CR	0D	13	-	2D	45	M	4D	77	m	6D	109
N	SO	0E	14	.	2E	46	N	4E	78	n	6E	110
O	SI	0F	15	/	2F	47	O	4F	79	o	6F	111
P	DLE	10	16	0	30	48	P	50	80	p	70	112
Q	DC1	11	17	1	31	49	Q	51	81	q	71	113
R	DC2	12	18	2	32	50	R	52	82	r	72	114
S	DC3	13	19	3	33	51	S	53	83	s	73	115
T	DC4	14	20	4	34	52	T	54	84	t	74	116
U	NAK	15	21	5	35	53	U	55	85	u	75	117
V	SYN	16	22	6	36	54	V	56	86	v	76	118
W	ETB	17	23	7	37	55	W	57	87	w	77	119
X	CAN	18	24	8	38	56	X	58	88	x	78	120
Y	EM	19	25	9	39	57	Y	59	89	y	79	121
Z	SUB	1A	26	:	3A	58	Z	5A	90	z	7A	122
[ESC	1B	27	;	3B	59	[5B	91	{	7B	123
\	FS	1C	28	<	3C	60	\	5C	92		7C	124
^	GS	1D	29	=	3D	61	^	5D	93	}	7D	125
^	RS	1E	30	>	3E	62	^	5E	94	~	7E	126
^	US	1F	31	?	3F	63	^	5F	95	DEL	7F	127

NUL	Null, or all zeros	VT	Vertical Tab	SYN	Sync.
SOH	Start of Header	FF	Form Feed	ETB	End Transmission Block
STX	Start of Text	CR	Carriage Return	CAN	Cancel
ETX	End of Text	SO	Shift Out	EM	End of Medium
EOT	End of Transmission	SI	Shift In	SUB	Substitute
ENQ	Enquiry	DLE	Data Link Escape	ESC	Escape
ACK	Acknowledge	DC1	Device Control 1	FS	File Separator
BEL	Bell or Alarm	DC2	Device Control 2	GS	Group Separator
BS	Backspace	DC3	Device Control 3	RS	Record Separator
HT	Horizontal Tab	DC4	Device Control 4	US	Unit Separator
LF	Line Feed	NAK	Negative Acknowledge	DEL	Delete

Appendix D – +FBU/+FDB/+FBU Interactions

Overview

The +FBU/+FDB/+FDD commands control how fax debugging information is sent to the DTE. There are three types of debugging that these commands control:

1. Allows a low level fax protocol frame information (with +FHR/+FHT responses as documented in the +FBU command description) to be displayed during the fax handshaking process and during non-ECM (error correction mode) fax page send/receives. (Defined in T.32 standard)
2. Allows +FHR/+FHT responses to be displayed while sending/receiving page data in ECM mode. (Non-standard Multi-Tech modems only)
3. Allows internal fax debugging (with +FDB responses as documented in the +FDB command description) to be displayed in a consistent manner so that fax applications or DTE's can log and otherwise safely ignore the debugging information/process. (Non-standard Multi-Tech modems only).

Notes:

- Depending on the level of firmware in the modem and the modem model number, these commands may not be available (even when updated to the latest firmware). Check your modem by using the following commands: AT+FDB=?, AT+FDD=?

If these commands are not implemented, the modem will issue either:

ERROR

or

00 and OK (indicates that the range of acceptable values is only zero)

- For a description of the +FBU command, see Chapter 2.

Table of +FBU/+FDB/+FDD Commands and How Their Values Interact:

+FBU=0		+FDD command values	
		0	1
+FDB command values	0	none	none
	1	case 3	case 3

+FBU=1		+FDD command values	
		0	1
+FDB command values	0	case 1	case 1
	1	cases 1,2	cases 1,2,3

Index

%	
%%	
literal % character in AT+FPH	52
%d	
day of month in AT+FPH	52
%h	
hour in AT+FPH	52
%i	
hour, 24-hr clock, AT+FPH	52
%j	
day of year in AT+FPH	52
%m	
month in AT+FPH	52
%M	
minute in AT+FPH	52
%p	
am or pm in AT+FPH	52
%P	
current page of fax in AT+FPH	52
%r	
ID of remote fax machine in AT+FPH	52
%s	
time seconds expression in AT+FPH	52
%t	
ID of transmitting fax machine in AT+FPH ..	52
%y	
year w/o century in AT+FPH	52
%Y	
year with century in AT+FPH	52
+	
+FAXERR	43
+FBO	45
+FBOR	45
+FBUF	53
+FDD debugging	36
+FDFFC	48
+FEA	46
+FHR	53
+FHR/+FHT debugging responses	65
+FHT	53
+FLNFC	49
+FLO	50
+FMINSF	44
+FMS	44
+FPHCTO	43
+FREL	46
+FV	51
+FVRFC	47, 48, 49, 50
+FWDFC	50
A	
action commands	11, 16
adaptive answer	17
Adaptive Answer parameter	42
Address & Polling Capabilities parameter	37
Addressing & Polling Frames parameters	38
Answer Call command	17
Answer parameter	42
answering a call	17
ASCII code	64
AT command implementation	5
AT command mode	7
AT+FPH	52
AT+FTD	51
B	
Bad Line Threshold parameter	42
Buffer Size parameters	53
C	
Call Termination with Status response	26
Capability to Receive parameter	35
Class 2 commands	
+FAA	42
+FBADLINL	42
+FBADMUL	41
+FBUG	35
+FCIG	33
+FCIG:	22
+FCLASS?	14
+FCLASS=	15
+FCLASS=?	14
+FCON	20
+FCQ	40
+FCR	35
+FCSI:	22
+FDCC=	28
+FDCS:	21
+FDCS?	29
+FDIS:	21
+FDIS=	29
+FDR	18
+FDT	17
+FDTC:	21
+FET:	25
+FHNG:	26
+FK	18

+FLID	33	+FPW.....	38
+FLPL	34	+FPW:.....	23
+FMDL?	15	+FRQ	41
+FMFR?	15	+FSA.....	38
+FNSC:.....	23	+FSA:.....	23
+FNSF:.....	23	+FSP.....	34
+FNSS:.....	23	+FTC:.....	21
+FPOLL.....	22	+FTI:.....	22
+FPTS.....	39	A	17
+FPTS:.....	24	D	16
+FRECV?	16	command execution mode.....	8
+FSPL.....	34	commands and responses.....	11
+FTSI:.....	22	Copy Quality Checking parameter.....	40
+FVOICE.....	25	Current Session Results parameters.....	29
A	17	Current Sessions parameters.....	29
D	16		
Class 2.1 commands		D	
+FAA	42	Data Bit Order parameters.....	45
+FAP	37	Data Compression Format Conversion	
+FBU.....	35	parameters.....	48
+FCC=.....	28	Data Reception command.....	18
+FCI:.....	22	data transfer mode.....	8
+FCLASS?	14	Data Transmission command.....	17
+FCLASS=.....	15	DCE Capabilities parameters.....	28
+FCLASS=?	14	DCE responses.....	11, 20
+FCO	20	debugging.....	65
+FCQ	40	DTE Phase C Response Timeout parameters.....	43
+FCR.....	35		
+FCS:.....	21	E	
+FCS?	29	Error Threshold Multiplier parameter.....	41
+FDM	20		
+FDR.....	18	F	
+FDT	17	Facsimile Connection response.....	20
+FET:.....	25	facsimile parameters.....	19
+FHS:.....	26	Fax Flow Control parameters.....	50
+FIP	19	Format conversion.....	47
+FIS:.....	21	frame information	21
+FIS=.....	29		
+FKS	18	I	
+FLI.....	33	identification commands.....	14
+FLP	34	Indicate Document to Poll parameter.....	34
+FMI?	15	Initialize Facsimile Parameters command.....	19
+FMM?	15	introduction.....	5
+FMR?	16		
+FNC:.....	23	L	
+FNF:.....	23	Local ID parameters.....	33
+FNR.....	37	Local Polling ID parameters.....	33
+FNS.....	34		
+FNS:.....	23	M	
+FPA.....	38	mandatory parameter commands.....	12
+FPA:.....	23	Minimum Phase C Speed parameters.....	44
+FPI	33	miscellaneous parameters.....	53
+FPI:.....	22	modes of interaction.....	7
+FPO.....	22		
+FPS.....	39	N	
+FPS:.....	24	Negotiation Reporting parameter.....	37

Non-standard frame FIF parameter..... 34

O

optional parameter commands..... 13

Originate command..... 16

originating a call..... 16

P

Page Header Generation..... 52

Page Length Format Conversion parameters . 49

Page Transfer Status parameter..... 39

Page Width Format Conversion parameters... 50

parameter commands..... 12, 28

Phase C Received EOL Alignment parameters

..... 46

polling 22

Post Page Message response 25

Post-Page Message Release command 18

Prefix Output On Query Response parameters

..... 51

R

Receive Page Transfer Status response..... 24

Receive Quality Thresholds parameter 41

remote IDs 22

Remote Polling Indication response..... 22

Report Addressing or Password strings

responses 23

Report DIS/DCS/DTC Frame Information

responses 21

Report Non-Standard Negotiation Frames

responses 23

Report Received HDLC Frames response..... 53

Report Remote ID responses.....22

Report Transmit HDLC Frames response53

Request Manufacturer Identification command15

Request Model Identification command..... 15

Request Revision Identification command.....16

Request to Poll parameter34

responses.....20

S

Service Class Capabilities command.....14

Service Class Indication command.....14

Service Class Selection command.....15

session message report responses53

Session Message Reporting parameter.....35

Session Termination command.....18

Set Current Time & Date.....51

T

T.30 Phase A negotiation responses20

T.30 Phase B negotiation responses21

T.30 Phase C Page Reception responses.....24

T.30 Phase D post page responses.....25

T.30 procedure control parameters.....39

T.30 Session Error Report parameters43

T.30 session parameter frames21

T.30 session parameters.....28

T.30 session subparameters.....30

Transition to data modem20

Transition to Voice response.....25

V

Vertical Resolution Format Conversion

parameters..... 47, 48, 49, 50